



Packet Synchronization over Carrier Ethernet Networks for Mobile Backhaul

A Formula for Deploying IEEE 1588v2 and Synchronous Ethernet: Investigate – Test - Deploy

January 2012

Version 1.0

MEF Positioning Paper

Table of Contents

1	Introduction	5
2	INVESTIGATE	5
3	TEST	11
3.1	Testing IEEE 1588v2 and Synchronous Ethernet Prior to Network Deployment.....	11
3.2	Testing IEEE 1588v2 and Synchronous Ethernet in the Deployed Network.....	18
4	DEPLOY	20
5	Summary	22
6	Glossary and Terms	22
7	References	23
8	About the MEF.....	24
9	Acknowledgements.....	24
10	Appendix A – Background and Introductory Information	25
10.1	MEF22.1 and Synchronization	27
11	Appendix B – ITU-T Synchronous Ethernet and the Ethernet Synchronization Messaging Channel (ESMC) Protocol.....	31
12	Appendix C - IEEE 1588v2, the Precision Timing Protocol	34
	Appendix D – IEEE 1588v2 Transparent Clock and Boundary Clock Tests.....	38

Table of Figures

Figure 1	IEEE 1588v2 Test Topology	13
Figure 2	Test setup for ITU-T G.8262 SyncE Wander.....	16
Table 4	ITU-T G.8262 SyncE Node Level Wander Tests	16
Figure 3	Test setup for ITU-T G.8262 SyncE Jitter.....	17
Table 5	ITU-T G.8262 SyncE Node Level Jitter Tests.....	17
Figure 4	IEEE-1588 and recovered clock tests.....	18
Figure 5	Synchronous Ethernet and recovered clock tests	19
Figure 6	Migration from SONET/SDH to SyncE	21
Figure 8	Designing your synchronization distribution architecture.....	22
Table 6	Synchronization Technologies and Traffic interfaces	25
Figure 9	Synchronization Distribution Architecture for TDM and Ethernet Base Stations	26
Figure 10	Evolution of Network Timing from TDM to SyncE.....	27
Figure 11	- Use Case 1a - Low Priority traffic with CES across MEN.....	28
Figure 12	Use Case 1b - All traffic with CES across MEN.....	29
Figure 13	Use case 2a - Low priority traffic with MEF 6.1 Service across MEN.....	29
Figure 14	Use case 2b - All traffic with MEF 6.1 Service across MEN	30
Figure 15	Frame Delay Variation over Time	31
Figure 16	Comparison between two Ethernet PHYs	32
Table 7	SSM Message Structure	33
Figure 17	ITU-T G.8261 Master/Slave Network Example.....	34
Table 8	PTP Event Message Types	35
Table 9	PTP General Message Types.....	36
Figure 18	IEEE 1588v2 Clock Hierarchy	37

Figure 19 Packet Delay in TC 38
 Figure 20 Congestion Traffic Test Set-up 39
 Figure 21 TC Test Configuration..... 40
 Figure 22 Boundary Clock 41
 Figure 23 Development Test Procedure 41
 Figure 24 Boundary Clock Wander Tests 42

Abstract

Mobile Backhaul refers to the network between Base Station sites and Network Controller/Gateway sites for all generations of Mobile Technologies. This document is based upon the MEF22.1 Mobile Backhaul Implementation Agreement Technical Specification¹, which identifies the requirements for MEF Carrier Ethernet Services and MEF External Interfaces for use in Mobile Backhaul networks. Where possible, it specifies frequency and phase synchronization requirements for packet based synchronization methods and ITU-T Synchronous Ethernet (SyncE).

The goal of this document is to provide technical managers and network designers insight into successfully deploying physical layer based Synchronous Ethernet and/or packet based methods using IEEE 1588v2 for frequency synchronization in their Carrier Ethernet mobile backhaul networks. It specifically focuses on methods to test and validate synchronization distribution architectures (SDA).

Tip for the Reader: This document assumes familiarity with the basics of IEEE 1588v2 and ITU-T SyncE technology. If you need an overview of these technologies, read Appendices B and C first.

This document takes a three step approach to aid operators as they begin to investigate, test and deploy synchronization in their packet networks.

- Section 2, INVESTIGATE, answers a series of questions frequently asked to identify synchronization distribution architectures and methods.
- Section 3, TEST, explores performance requirements and testing guidelines for the synchronization distribution architecture.
- Section 4, DEPLOY, has example deployments of synchronization distribution architecture.

Supplementary details are included in the Appendices:

- Appendix A provides introductory information about synchronization, explaining the evolution of distributing frequency synchronization over packet based backhaul networks/SDAs.

¹ MEF 22.1 Mobile Backhaul Implementation Agreement Phase 2 Technical Specification

- Appendix B provides more technical details behind ITU-T Synchronous Ethernet (SyncE) and the Ethernet Synchronization Messaging Channel Protocol (ESMC).
- Appendix C describes IEEE 1588v2 messages and descriptions of the four clock types essential for this method.
- Appendix D evaluates the functionality and performance testing of IEEE 1588v2 Transparent Clocks and Boundary Clocks, items currently being studied by the ITU-T Study Group 15 (Question 13).

Synchronisation in packet networks can also be delivered using other technologies, such as Network Timing Protocol (NTP), Circuit Emulation Services (CES) or Global Navigation Satellite Systems (GNSS), but these are not in the scope of this version of the document.

1 Introduction

In mobile backhaul networks, different technology generations — 2G TDM, 3G ATM/Ethernet, 4G IP/Ethernet — are delivered simultaneously over the same transport network. While offering similar end-user services, these mobile technologies have different synchronization requirements.² For example, accurate time or phase is required in CDMA, Universal Mobile Telecommunications Systems (UMTS) Time Division Duplex (TDD), LTE TDD and WiMAX, but is not needed in Global System for Mobile Communications (GSM) and UMTS Frequency Division Duplex (FDD).

Mobile operators face many challenges when implementing network convergence, one of which is synchronizing base stations. In the past, a centralized primary reference clock along with TDM E1/T1 backhaul links, or distributed primary reference clocks using Global Positioning System (GPS) US Global Navigation Satellite Systems (U.S. GNSS), were the technologies used to synchronize base stations. With the migration to Ethernet/IP backhaul, and concerns about relying only on GPS, methods based on protocols like IEEE 1588v2, Network Timing Protocol, Circuit Emulation Services and SyncE, have been developed and deployed to deliver frequency synchronization and, in the case of IEEE 1588v2 and NTP, time synchronization over Ethernet.

SyncE and IEEE 1588v2 are the focus and scope of this document³.

Tip for the Reader: This document takes a three step approach to aid operators as they begin to investigate, test and deploy IEEE 1588v2 and/or SyncE synchronization in their packet-based backhaul networks/SDA. Section 2, INVESTIGATE, answers a series of questions frequently asked to identify synchronization approaches. Section 3, TEST, explores testing guidelines for equipment manufacturers and tests operators can do in the network in order to identify problems before the service goes live. Section 4, DEPLOY, summarizes the document with how standards organizations and customers are using packet synchronization technologies. Details behind these standards and synchronization technologies are included in the Appendices.

2 INVESTIGATE

This section covers some of the common questions that are asked when investigating migration to delivering frequency synchronization for Mobile Backhaul.

Why migrate synchronization distribution architectures?

To deliver timing from a primary reference master clock (PRMC) to many slave clocks at Base Stations (BS), a synchronization distribution architecture (SDA) always uses a tiered or hierarchical approach. This paper assumes the reader is familiar with the motivation behind migrating to Ethernet Services for Mobile Backhaul and the need to meet synchronization

² MEF 22.1, Mobile Backhaul Implementation Agreement Phase 2, Technical Specification, Table 7

³ Even though GNSS technologies are not in the scope of this document, they will play a fundamental role in the future as PRTC (i.e. reference for a PTP distribution chain), or in distributed architectures where, for instance, requirements might be too stringent to be fulfilled by a reference distributed over the network.

requirements at the base station, and explores some of the drivers and technical challenges in making this move. Background information on industry and technology drivers, as well as Synchronous Ethernet and IEEE-1588v2 are described in Appendices A, B, and C.

What are the differences from TDM synchronization distribution architectures?

A SONET/SDH based TDM network is synchronous by design since it manages timeslot switching. In contrast, typical IEEE based Ethernet networks are asynchronous, meaning network elements are independent of each other in the network when forwarding frames through a node. New protocols and technologies have been ratified by standards organizations so that a packet network can support the delivery of network synchronization to meet BS requirements. With packet based methods, clock recovery algorithms at slave clocks use the arrival rate of packets or timestamps to compensate for network impairments such as packet or frame delay.

How is the synchronization distribution architecture evaluated?

Performance of the SDA is evaluated for the chain of clocks, from the primary reference source (i.e., master clock) to the slave clock at the BS site, to achieve required parts-per-billion (ppb) accuracy. Recommendations for networks are defined for TDM (ITU-T G.823/824/825) and Packet Networks (ITU-T G.8261).

Performance is also important to understand for SyncE and a single clock implementation, i.e., network equipment with oscillator. For SyncE, the Ethernet End Equipment (EEC) can be in free running mode, i.e., with 4.6ppm accuracy, or can operate locked to a network clock, which is relevant when a network failure forces the oscillator to be in holdover mode for a certain period of time, e.g., 4 or 24 hrs or days. For single clock performance of network equipment, recommendations, metrics and limits are defined for both TDM (ITU-T G.813) and Ethernet (ITU-T G.8262).

Table 1 summarizes standalone network equipment and network recommendations that can be used as guidance for TDM and Ethernet network deployments.

Table 1 TDM and Ethernet Wander Performance Recommendations for Timing

	<i>Standalone Network Equipment</i>	<i>Entire Network</i>
TDM	ITU-T G.813	ITU-T G.823/824/825
Ethernet	ITU-T G.8262	ITU-T G.8261 plus Standalone EQ recommendations G.813 and G.8262

Accuracy: ppm or ppb?

There is some confusion about the fact that transport technologies such as PDH and SyncE are often quoted to meet ± 4.6 parts per million (ppm) accuracy while the end applications require ppb accuracy. Table 2 summarizes the mobile technology application accuracy requirements.

Table 2 Frequency and phase accuracy requirements of the Air Interface for different mobile technologies and the backhaul network

Mobile Technology	Frequency	Phase/Time
CDMA2000	± 50 ppb	Goal: $< 3\mu s$ Must Meet: $< 10\mu s$ for not less than 8 hours, with respect to CDMA System Time (traceable to UTC)
GSM	± 50 ppb	N/A
WCDMA-FDD	± 50 ppb	N/A
WCDMA-TDD	± 50 ppb	$2.5\mu s$
TD-SCDMA	± 50 ppb	$3\mu s$ inter-cell phase difference
LTE (FDD)	± 50 ppb	N/A
LTE (TDD)	± 50 ppb	$3\mu s$ inter-cell phase difference for small cells, $10\mu s$ for large cells
LTE MBMS	± 50 ppb	** $1\mu s$ inter-cell phase difference
FemtoCell	± 250 ppb	N/A
WiMAX (TDD)	± 2 ppm absolute, $\sim \pm 50$ ppb between base stations	Typically $1 - 1.5\mu s$

So what does the ± 4.6 ppm refer to? It refers to the accuracy of a standalone device or interface in what is called ‘free-run’ state. In a SDA, the Primary Reference Clock (PRC) is used to

synchronize all elements to deliver ppb accuracy or better (i.e. 10^{-11}). If SyncE or PDH is synchronized by a PRC, they should deliver 'ppb' accuracy.

If a device or interface loses synchronization to the PRC, the standards specify that it should still be able to deliver ± 4.6 ppm after a specified free-run period. In a real network, being correctly synchronized to a PRC ensures that Ethernet or TDM can deliver ppb accuracy.

What standards are there and why?

Standards and recommendations exist to specify the framework, the protocols as well as the performance requirements for Synchronization.

MEF 22.1

Phase 1 of MEF 22.1¹ described a framework for using MEF 6.x Ethernet and MEF 8 CES services for Mobile Backhaul. Performance of synchronization architectures was limited to the case with TDM interfaces to base stations.. Phase 2 of MEF-22.1, currently in progress, adds enhancements for interoperable deployments of service as well as synchronization performance. Enhancements include the UNI Mode attribute, to lock SyncE to an EEC and to make sure interoperations of SyncE include a clock quality level (QL), synchronization as a class of service, and enhancements to the Class of Service mapping table. MEF-22.1 references ITU-T and IEEE standards for all relevant requirements.

ITU-T

ITU-T G.81x and ITU-T G.82x

Performance specifications for TDM networks and synchronization are contained within the ITU-T G.81x and ITU-T G.82x Series of Recommendations. They specify frequency accuracy metrics of Maximum Time Interval Error (MTIE) and Time Deviation (TDEV) with limits in the order of nanoseconds, which correspond with the requirement to deliver ppb accuracy . There are different masks for the accuracy that a signal is expected to deliver in the ITU-T G.823 recommendation. For example, there are tighter limits for a PRC than there are for a Traffic Interface. For more details on these metrics, refer to Section 3.1.2 under Measurements and Limits.

ITU-T G.781 and ITU-T G.8264

ITU-T G.781 describes a clock hierarchy deployment model as well as a clock selection process for TDM networks. This has been reprised by the ITU-T G.8264 recommendations, which covers the same aspects for an Ethernet synchronization network.

ITU-T G.82xx

The development and evolution of the ITU-T G.82xx recommendations forms the core work of the ITU-T study group responsible for synchronization. This includes defining the ITU-T Telecom profile for Time of Day transfer and establishing performance metrics and limits.

The series broadly covers the different requirements of providing synchronization over packet networks. ITU-T G.8261 defines SyncE network limits and describes the framework for deploying Synchronization in a packet network, including recommended pre-deployment test

cases. ITU-T G.8262 includes the performance requirements for synchronous EEC accuracy, in parallel to the ITU-T G.81x and ITU-T G.82x series mentioned above. ITU-T G.8264 adds the Ethernet Synchronization Messaging Channel (ESMC) protocol to manage the hierarchy and deployment of SyncE. ITU-T G.8265 and ITU-T G.8265.1 define the ITU-T Telecom Profile for frequency transfer (for example by using IEEE 1588v2).

IEEE-1588 (2008)

Also called 1588v2 or Precision Timing Protocol (PTP), IEEE-1588v2 standardizes a Precision Clock Synchronization Protocol for Networked Measurement and Control Systems. This protocol was adopted and further defined by the ITU-T for deployment in Telecom networks:

- ITU-T G8265.1 Recommendation describes the deployment of IEEE-1588v2 in Telecom networks for frequency transfer.
- ITU-T G.8275.1 Recommendation , which is currently being worked on, will describe the deployment of IEEE-1588v2 in Telecom networks for Time-of-day transfer.

Should we choose SyncE and/or IEEE 1588v2?

Selecting SyncE or IEEE 1588v2 depends on whether the mobile technology application needs frequency or frequency and phase, as shown in Table 2. SyncE is a physical layer technology that delivers a frequency reference, whereas IEEE 1588v2 delivers time from which both phase and frequency can be derived. There are some caveats:

- SyncE cannot be deployed on legacy Ethernet networks unless the physical hardware or interfaces are all upgraded. This may limit its deployment across operator boundaries or national boundaries. On the plus side, it is not affected by network impairments such as frame delay range (FDR).⁴
- IEEE 1588v2 can be deployed with legacy Ethernet NEs not implementing the protocol, but clock recovery algorithms at slave clocks need to function well in the presence of network impairments that can vary significantly with traffic load.

There is growing interest in deploying both IEEE 1588v2 and SyncE together and also in deploying IEEE 1588v2 even when the technology only needs frequency sync. A stable SyncE frequency synchronization can be used to discipline the slave clock oscillator even in the presence of significant network impairments, although methods for implementing this are currently vendor-specific.

What is the field experience with these technologies/protocols?

Operators have deployed MEF compliant services and have also supported frequency synchronization over packet networks. For example, with MEF 18 certification to support MEF 8 services, an Operator can confidently roll out a packet network to support legacy base stations with TDM demarcation.

⁴ MEF 10.2, MEF 22.1

Phase 2 of MEF 22.1 further specifies interoperability requirements for SyncE. It is possible to have MEF compliant UNIs by Mobile Operators (UNI-C) as well as by Metro Ethernet Network (MEN) Operator equipment (UNI-N). Packet methods using IEEE 1588v2, SyncE as well as vendor-specific protocols have been used in live networks. Clock recovery algorithms are constantly being improved to deliver reliable synchronization under different network topologies and conditions.

To give network designers and operators confidence to migrate to these technologies, standards and recommendations continue to be developed. Nevertheless, there remains work to be done to truly characterize the evolution of Carrier Ethernet networks and understand their impact on Synchronization. As these technologies are more widely and regularly deployed, knowledge will be gained on monitoring and maintaining accuracy and performance in the network.

Will it work in MY network?

Implementing a comprehensive test plan prior to deployment is an important part of building confidence that any new technology will work in a live environment. MEF 22.1 compliant implementations, coupled with the suggested tests in this white paper, should provide a sound basis for a successful SDA. Using test tools, characteristics, such as network impairments from real networks, can be emulated in the lab to prove the technologies for real network deployment.

Section 3 explores testing that can be done in the network to identify problems before the service goes live, or for troubleshooting.

Will IEEE 1588v2 Transparent Clocks or Boundary Clocks help?

Frequency synchronization is deployed in networks today without transparent clock (TC) and boundary clock (BC) functionality. However, time synchronization without TCs and/or BCs can be a significant challenge in some scenarios.

In the Telecom community, there is general acceptance that TCs and BCs are essential to deliver accurate time synchronization via a packet network. ITU-T study group 15 (Question 13) is working to define a profile for Time of Day (ToD) transfer that is likely to include TC/BC support as well as architecture guidelines, functionality and performance limits.

Fundamental challenges to clock recovery are network impairments like FDR, and in the case of time synchronization, asymmetries. TCs and BCs can help reduce the impact of network impairments that a slave clock has to deal with, thereby helping achieve accurate clock recovery in a network. Nevertheless, some sources of asymmetry remain, like different cable lengths in the Uplink and Downlink paths. Asymmetry can have an impact on the accuracy of the recovered time synchronization, but is not an issue for frequency synchronization.

It is important to note that while IEEE 1588v2 defines the functional model for BC and TC devices, there are no performance specifications defined in any Standards document. To address this, the ITU-T is working to define performance specifications for network elements with clock implementations for TCs and BCs.

Initial high-level specifications to verify correct operation and to prove the performance of TCs and BCs are reflected in the tests suggested in Appendix D.

3 TEST

Tip for the Reader: The **TEST** section forms a significant part of this paper and covers testing before, during and after deployment in some detail. If you are more interested in the Deployment of these technologies, please refer to Section 4 – Deploy.

This section examines testing done to verify implementations of the synchronization protocols specified. Testing can be done in a lab environment or in a network prior to turning up live service, and on live service already deployed in the network.

3.1 Testing IEEE 1588v2 and Synchronous Ethernet Prior to Network Deployment

There are three broad categories to be tested:

- Functional testing
- Performance testing to prove robustness of the network/SDA
- Interoperability testing

3.1.1 Functional Protocol Tests

Functional protocol tests are used to confirm master clock and slave clock conformance in the following areas:

- Modes of operation for the exchange of PTP messages
- PTP protocol mapping
- PTP message rates
- Unicast transmission and negotiation
- Alternate BMC algorithm
- Forced traceability of master clock
- Slave protection functions
- Clock Identity and PTP message format

3.1.2 System Performance Tests

System performance testing can be done on standalone equipment or on a network basis, as seen in Table 1.

3.1.2.1 IEEE 1588v2 Performance Testing

Done during the equipment system test phase or an operator pre-deployment lab trial, the performance testing of IEEE 1588v2 involves proving robust network operation, i.e. the ability to recover time and or frequency performance required by the end equipment, as specified in Table 1 and Table 2.

The Frame Delay Range (FDR), which is similar to Packet Delay Variation (PDV), defined in ITU-T Y.1541 for IP Packets and ITU-T Y.1563 for Ethernet frames, can be used to give some indication of the challenge level of the network to IEEE 1588v2 slaves. However, the delay variation of the fastest-packet population over specific time intervals finally determines the clock performance. ITU-T Study Group 15, Question 13 is currently working on suitable metrics and corresponding tolerance masks in detail.

ITU-T G.8261 – Appendix VI

Published by the ITU-T in April of 2008, the ITU-T G.8261 recommendation specifies a framework for transporting timing across an Ethernet network using technologies such as IEEE 1588v2. This standard also includes a test methodology for evaluating these technologies for network robustness in Appendix VI, for information.

ITU-T G.8261 Appendix VI is of particular interest to test engineers as it emulates multiple network scenarios. It provides a suite of tests to evaluate the performance of clock recovery under different kinds of network topologies, traffic characteristics and impairments.

Test Topology

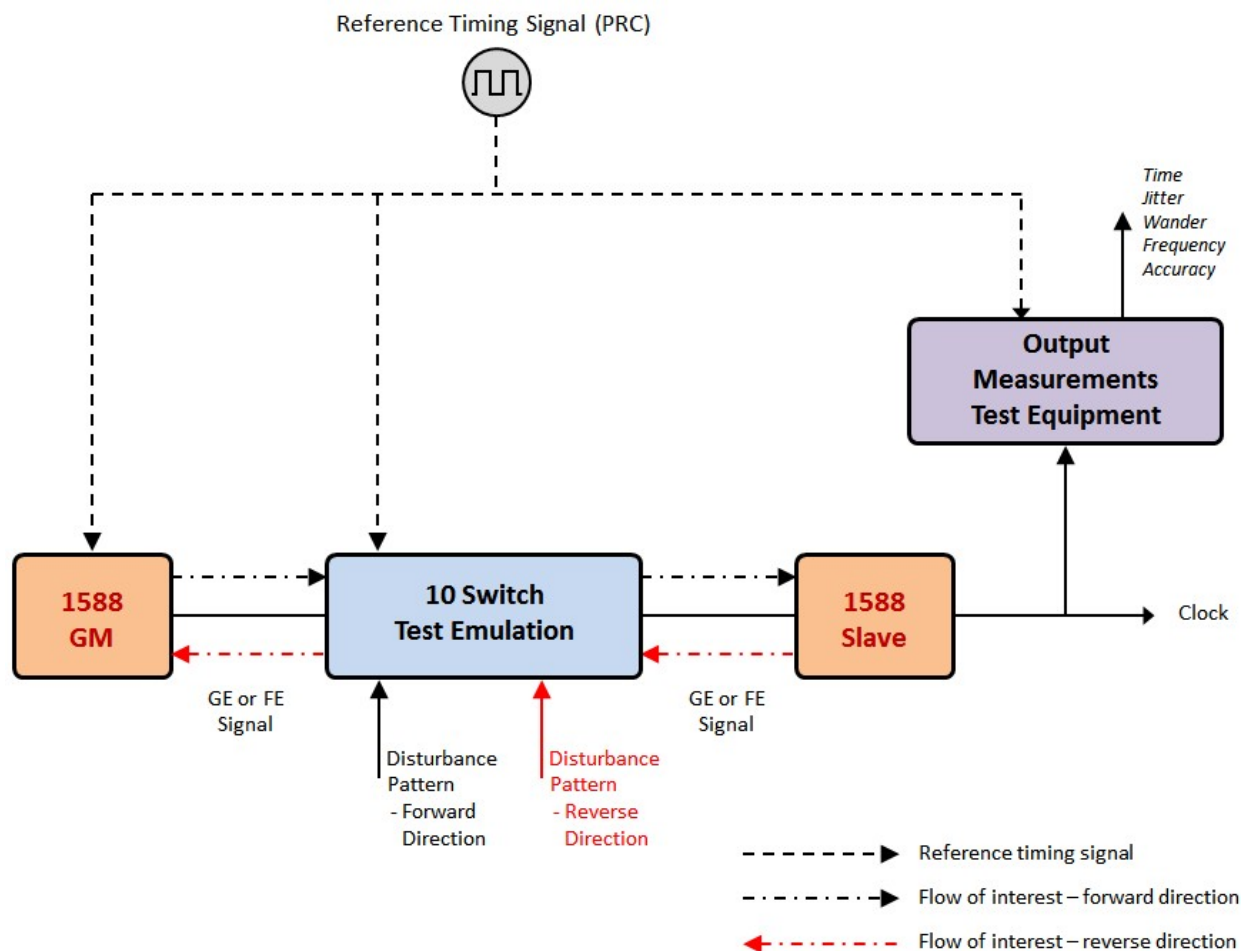

Figure 1 IEEE 1588v2 Test Topology

Figure 1 is a conceptual model that does not describe a specific implementation. It is considered for use to test transfer of frequency using IEEE 1588v2. In addition, the incorporation of TCs and BCs requires a suitable combination of these performance tests and the TC/BC tests suggested in Appendix D – IEEE 1588v2 Transparent Clock and Boundary Clock Tests.

A disturbance pattern, as input to the Test Equipment, could be one of many things: a FDR profile from either a file or an algorithm, a fixed latency, the introduction of errored packets, repeated packets, or any combination of these effects. These effects will impair the flow of interest as it passes from the IEEE 1588v2 master to the slave under test.

Impairments

Packet impairments are lost packets, mis-ordered packets, re-ordered packets, etc. Performance testing can include packet impairments applied to IEEE 1588v2 timing transfer packets by a network impairment device.

Measurements and Limits

To compare the original clock time signature to a time signature that has passed through the network for applications that transfer frequency, a wander measurement instrument is used. Time of day error is measured for applications that use IEEE 1588v2 to transfer time. The measurements include:

- Frequency Accuracy (Wander), based on:
 - TIE - time interval error
 - MTIE - maximum time interval error
 - TDEV – time deviation
- PDV or Frame Delay Variation (FDV)
- ToD error

TIE is the time difference between the network reference clock and a measured clock signal after a period of ‘S’ seconds.

The measurement limits for Frequency Accuracy are specified by the relevant ITU-T standards that specify clock accuracy. The limits/masks to be used should be according to the requirement of the signal under test as specified in ITU-T G.823. For example, a signal to be used as a PRC should be tested to the PRC limits as illustrated below in Table 3.

Table 3 Suggested MTIE/TDEV Masks based on Signal Use

Signal Use	Suggested ITU-T Mask
PRC - Primary Reference Clock	G.823/G.824 PRC
SEC- SDH Equipment Clock	G.823 SEC
EEC – Ethernet Equipment Clock	G.8262 Opt1/Opt2
Traffic Interface (E1/T1/Ethernet)	G.823/G.824 Network Interface

Measurement limits for packet-based methods are the subject of extensive work being done by the ITU-T Study Group responsible for the deployment of IEEE 1588v2 in networks. This group is working on developing limits and metrics in the packet domain under the ITU-T G.8260 recommendation, to be published in the near future.

Measurement limits for ToD errors are specified by the requirements of the end-application. For example, most wireless technologies that use ToD to derive phase synchronization have a requirement of $\pm 3\mu\text{s}$ phase accuracy between adjacent base stations. Therefore a single base station must be synchronized to better than $1.5\mu\text{s}$, which becomes the measurement limit for ToD test. As it is phase accuracy that needs to be delivered, it is phase error that needs to

measured, which can be done by comparing a 1pps output against a reference. As mentioned above, the current ITU-T G.8261 test methodology is primarily considered for testing the transfer of frequency.

3.1.2.2 Synchronous Ethernet Performance Testing

SyncE performance testing is governed by the ITU-T G.8262 and ITU-T G.8261 recommendations, which specify all test methods and measurement limits for standalone equipment and networks, respectively.

SyncE is also governed by ITU-T G.8264, which specifies the ESMC and its use in managing SyncE deployments and nodes, as detailed in Appendix B – ITU-T Synchronous Ethernet and the Ethernet Synchronization Messaging Channel (ESMC) Protocol. Specific aspects of ESMC protocol testing are not covered in this document, but the use of ESMC alongside performance testing to ITU-T G.8262 is noted below.

These tests evaluate the accuracy of frequency synchronization delivered by SyncE equipment and networks and their jitter performance. They also test the tolerance of this equipment to network jitter and wander and their contribution to total network performance.

Wander Tests

Frequency accuracy/wander (MTIE/TDEV) performance of an EEC, its tolerance to wander in a network, its amplification of wander and its response to a clock shift should all be evaluated at the node level as per ITU-T G.8262..

The test setup for SyncE wander is shown below in Figure 2:

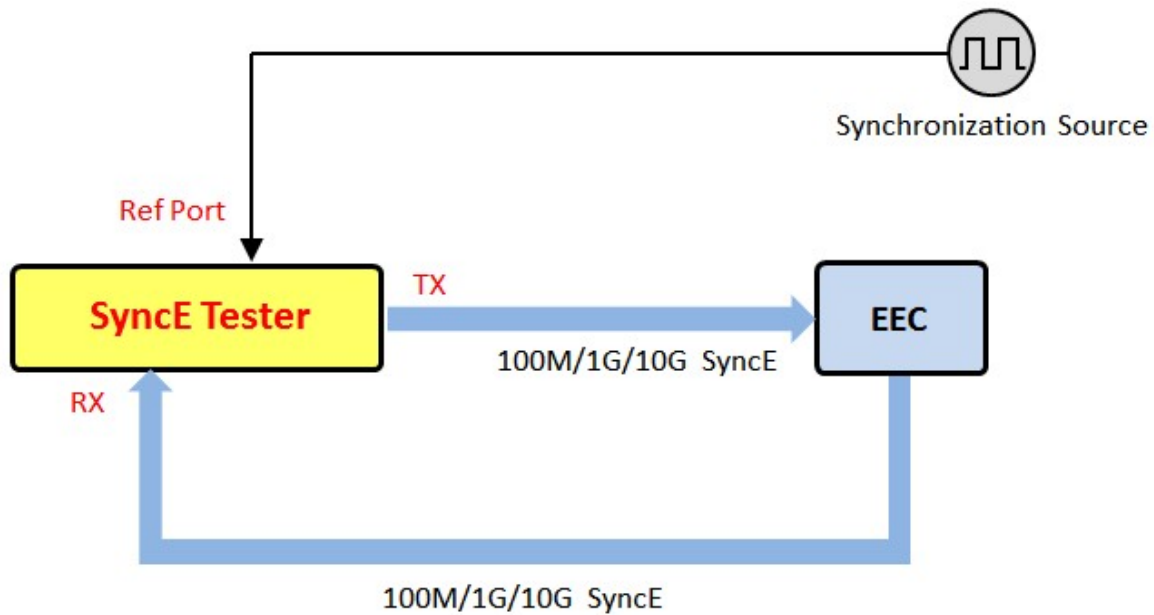

Figure 2 Test setup for ITU-T G.8262 SyncE Wander

Table 4 lists the frequency accuracy/wander tests that need to be run. Note that SyncE is measured on the Rx port, and ESMC can be monitored to see if it is compliant with ITU-T G.8264.

Table 4 ITU-T G.8262 SyncE Node Level Wander Tests

Test	TX Port	Measurement on Rx port
Pull-in/Pull-out Range	Offset SyncE clock by ± 4.6 ppm	MTIE/TDEV within ITU-T G.8262 Limits
Wander Generation	Transmit Reference SyncE	MTIE/TDEV within ITU-T G.8262 Limits
Wander Tolerance (EEC Option 1)	Add Wander as per ITU-T G.8262 Tables 7,8 and 9	- No alarms/errors - MTIE/TDEV within ITU-T G.8261 Limits
Wander Tolerance (EEC Option 2)	Add Wander as per ITU-T G.8262 Table 10	- No alarms/errors - MTIE/TDEV within ITU-T G.8261 Limits
Wander Transfer (EEC Option 1)	Add Wander as per ITU-T G.8262 Table 9	Measure Gain < 0.2dB
Wander Transfer (EEC Option 2)	Add Wander as per ITU-T G.8262 Table 10	Measure TDEV as per ITU-T G.8262 Table 11
Phase Transient Response (EEC Option 1)	Act as SyncE Master. Generate ESMC (PRC) and then change to (e.g.) ESMC-DNU, forcing DUT to switch to secondary reference	Measure TIE as per ITU-T G.8262 Fig. 12
Phase Transient Response (EEC Option 2)	Act as SyncE Master. Generate ESMC (PRC) and then change to (e.g.) ESMC-DNU, forcing DUT to switch to secondary reference	Measure MTIE as per ITU-T G.8262 Table 15

Additional tests also exist for performance in holdover, during signal interruptions, and Phase discontinuities in ITU-T G.8262.

Jitter Tests

Jitter performance of an EEC, which specify limits for the output jitter of a device and its tolerance to jitter, were added into ITU-T G.8262 in July 2010. Figure 3 shows the test set-up diagram for SyncE jitter, and Table 5 shows the SyncE node level jitter tests.

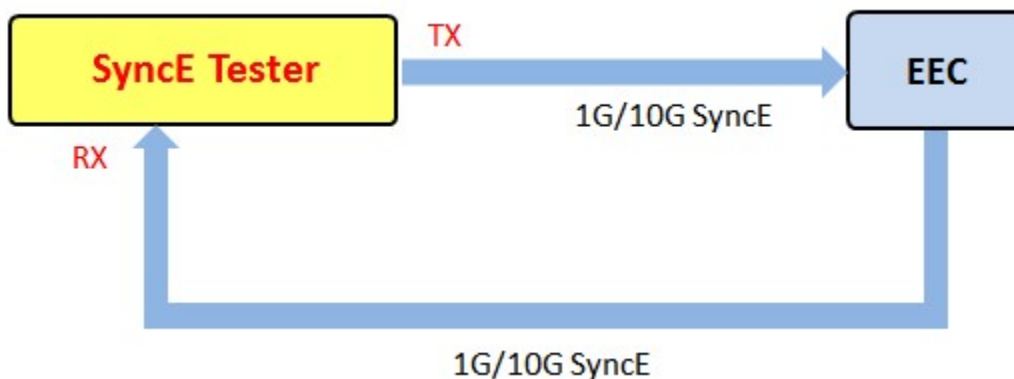

Figure 3 Test setup for ITU-T G.8262 SyncE Jitter

Table 5 ITU-T G.8262 SyncE Node Level Jitter Tests

Test	TX Port	RX Port	Measurement
Jitter Generation	Transmit Reference SyncE	Measure SyncE Jitter	Jitter (Pk-Pk) < 0.5UI
Jitter Tolerance	Add Jitter as per ITU-T G.8262 Tables 11 and 12	Monitor	No alarms/errors

3.1.3 Interoperability Testing

When mobile operators plan to deploy equipment from multiple vendors, they typically perform a number of tests to ensure each piece of equipment operates correctly with the other pieces of equipment to which it is directly interconnected. Equipment manufacturers also run Interoperability testing to ensure there are no issues between different models and/or ranges of products that they produce.

Interoperability testing closely mirrors the in Functional Protocol Tests described in Section 3.1.1. Interoperability problems primarily result from different interpretations of the Standards and are most likely associated with the field values produced or the reaction to the receiving fields set in various states. While the type of testing appears to have a significant overlap with

the testing done on a nodal basis, it is prudent to re-run all the functional tests to ensure interoperability.

3.2 Testing IEEE 1588v2 and Synchronous Ethernet in the Deployed Network

Section 3.1 described tests done in a lab environment for standalone network equipment, including interoperability to verify functional interconnectivity. These tests are done prior to the equipment being installed into the working network.

During deployment installation, the operator performs turn-up testing on each link to ensure accurate synchronization is being delivered. Once the SDA is verified, tests and system performance monitoring are done on a routine and scheduled basis to assure high quality and that service level agreements are met.

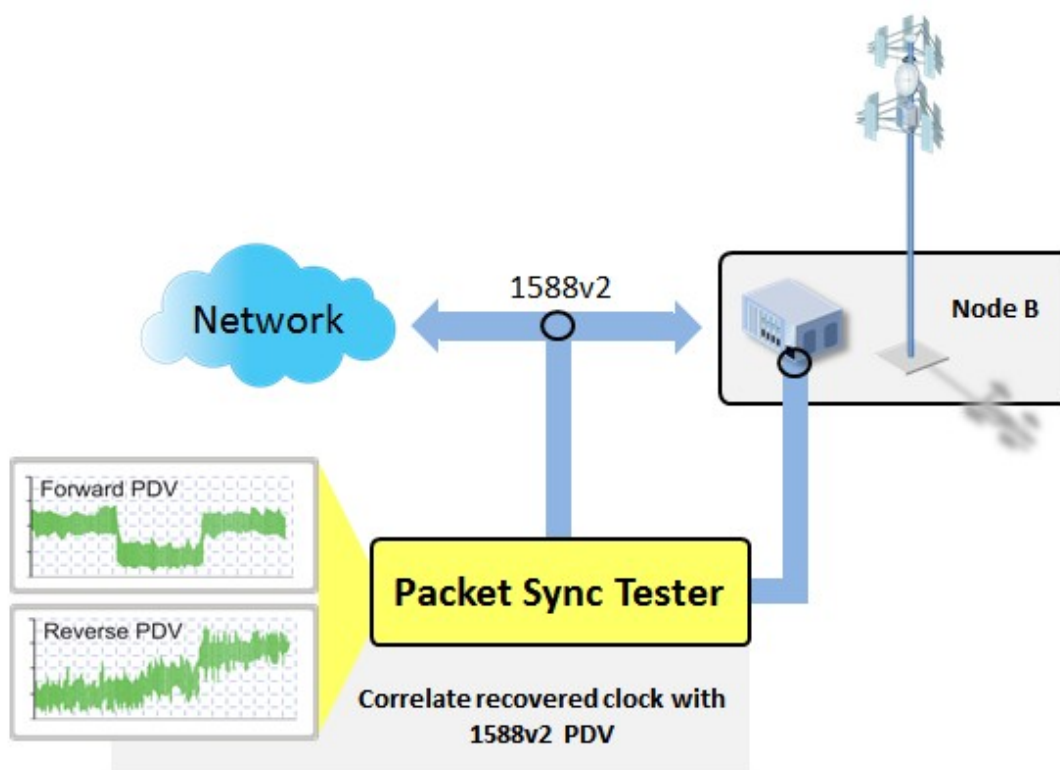

Figure 4 IEEE-1588 and recovered clock tests

3.2.1 IEEE-1588v2 in the deployed network

Figure 4 illustrates testing PTP (IEEE-1588) during installation and after deployment to ensure key performance indicators are within required limits. Three are listed below:

1. For frequency accuracy, the recovered E1/T1 frequency is measured to determine its accuracy as defined in ITU-T G.823/G.824 and shown in Table 3. . Other recovered frequencies can also be tested to limits traceable to the same recommendations.
2. For time transfer accuracy, the recovered 1pps is measured and checked against relevant limits (e.g. 1.5µs for TD-SCDMA).
3. To determine the bi-directional FDR of IEEE 1588v2 messages, the Forward (SYNC) FDR and Reverse (DELAY_REQ) FDR are measured. IEEE 1588v2 packet metrics are then applied to determine the impact of the network FDR on the quality of the recovered clock.

Any failures found in steps 1) and 2) should be correlated with the FDR measurements found in step 3) to assist in the troubleshooting and for future network design and baselining.

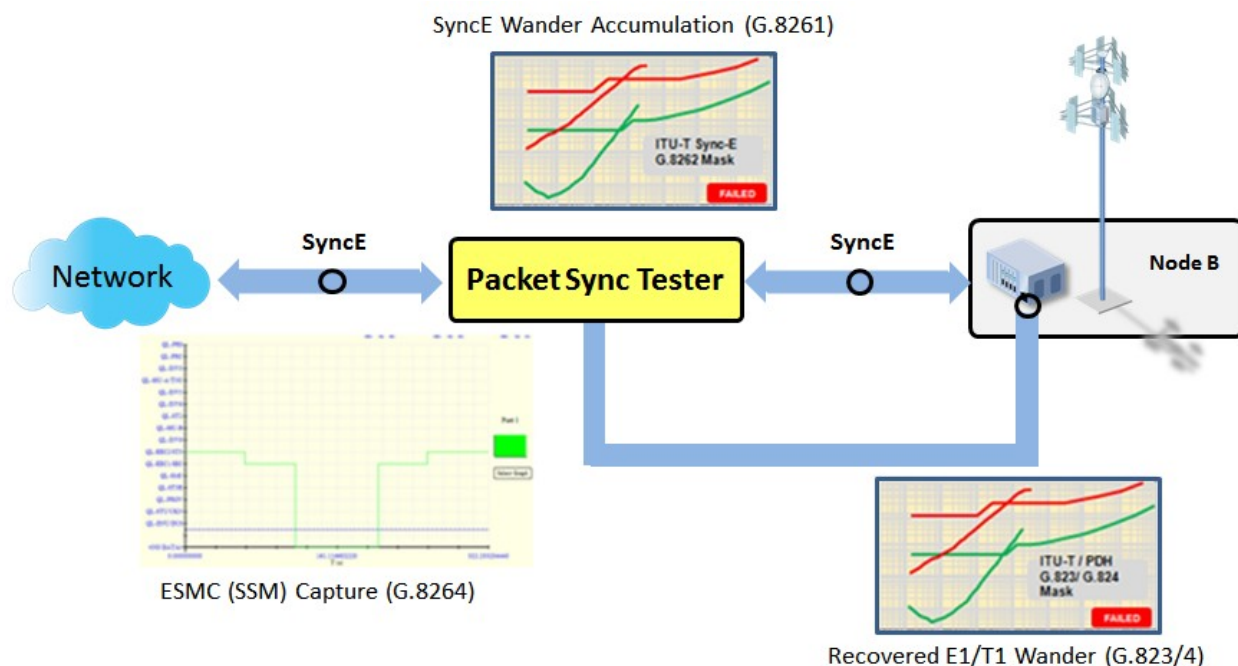

Figure 5 Synchronous Ethernet and recovered clock tests

3.2.2 SyncE in the deployed network

Figure 5 illustrates testing SyncE during installation and after deployment to ensure key performance indicators are within required limits.

- For frequency accuracy, the recovered E1/T1 frequency is measured to determine its accuracy as defined in ITU-T G.823/G.824 and shown in Table 3.. Other recovered frequencies can also be tested to limits traceable to the same recommendations.
- Wander and jitter are measured to ensure the performance is within ITU-T G.8261 limits.

- The ESMC flow is monitored within the SyncE network to capture SSM messages in order to monitor clock quality level (QL) as well as clock switching performance (if present).

4 DEPLOY

So which technology should be deployed? One size certainly doesn't fit all and it is likely that a mobile network will deploy a combination of synchronization technologies. TDM or GNSS may be maintained in a minority of sites where it is the only option. Increasingly, networks and services will require not just frequency but also accurate time synchronization. There are only two options to deliver time – GNSS/GPS or packet-based timing like IEEE 1588v2. Given the growing concern with cost, coverage and security of GPS, the growth in deployment of IEEE 1588v2 in Carrier Ethernet Mobile Backhaul networks is inevitable. There is growing interest in deploying both IEEE 1588v2 and SyncE so that the stable SyncE frequency synchronization can be used to discipline the time synchronization if there are IEEE 1588v2 PTP issues caused by excessive FDV in the network.

There is also a fair amount of discussion on how a network/SDA is deployed. Where should the Grandmasters be located? How many hops between Grandmaster and Slave? How many Slaves can a Master support? Until all related rules are defined in the relevant standards, experimentations and trials will be required. By conducting thorough lab testing and network testing as recommended in this document, an operator can establish the guidelines for deployment of IEEE 1588v2 and/or SyncE in their network. This is a key discussion topic for the ITU-T Study Group 15, Question 13.

It is generally accepted that deployments of IEEE 1588v2 in networks to deliver time is likely to require the use of TCs and/or BCs. Once the performance of these devices has been characterised, they can be deployed according to the SyncE planning guidelines, based on ITU-T recommendations currently used to deploy SONET/SDH networks.

One option is to upgrade a SONET/SDH network to Ethernet link by link based on bandwidth demand. SyncE follows the same hierarchy and deployment rules as existing SONET/SDH for frequency synchronization, making it very easy to deploy using existing best practices and synchronization distribution architectures. Figure 6 below shows how SyncE can be introduced and deployed in an existing SONET/SDH network, creating a Hybrid SDA.

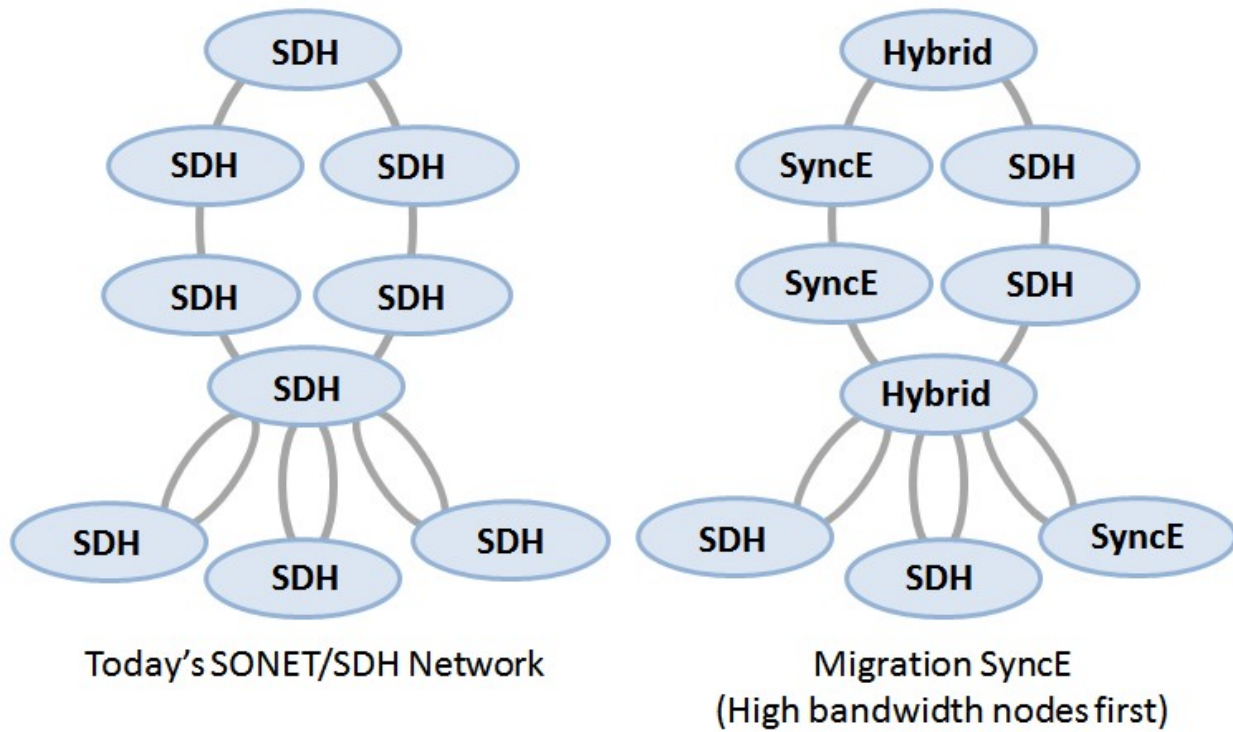

Figure 6 Migration from SONET/SDH to SyncE

Figure 7 below shows how the existing BITS clocking architecture within SONET/SDH can serve both SyncE and the legacy network.

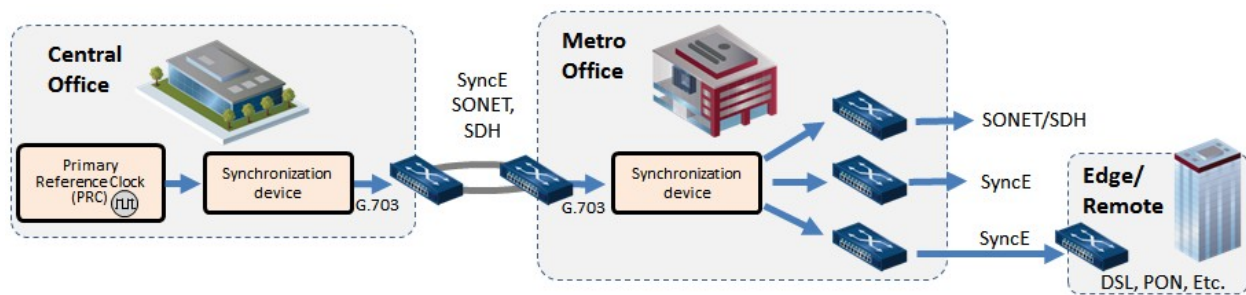

Figure 7 How existing SSU/BITS architecture serves SyncE and legacy

With IEEE 1588v2, the operator is currently required to take a test-and-deploy strategy to determine the SDA most suited to their requirements. In the future this strategy will evolve, once additional rules are defined by relevant specifications.

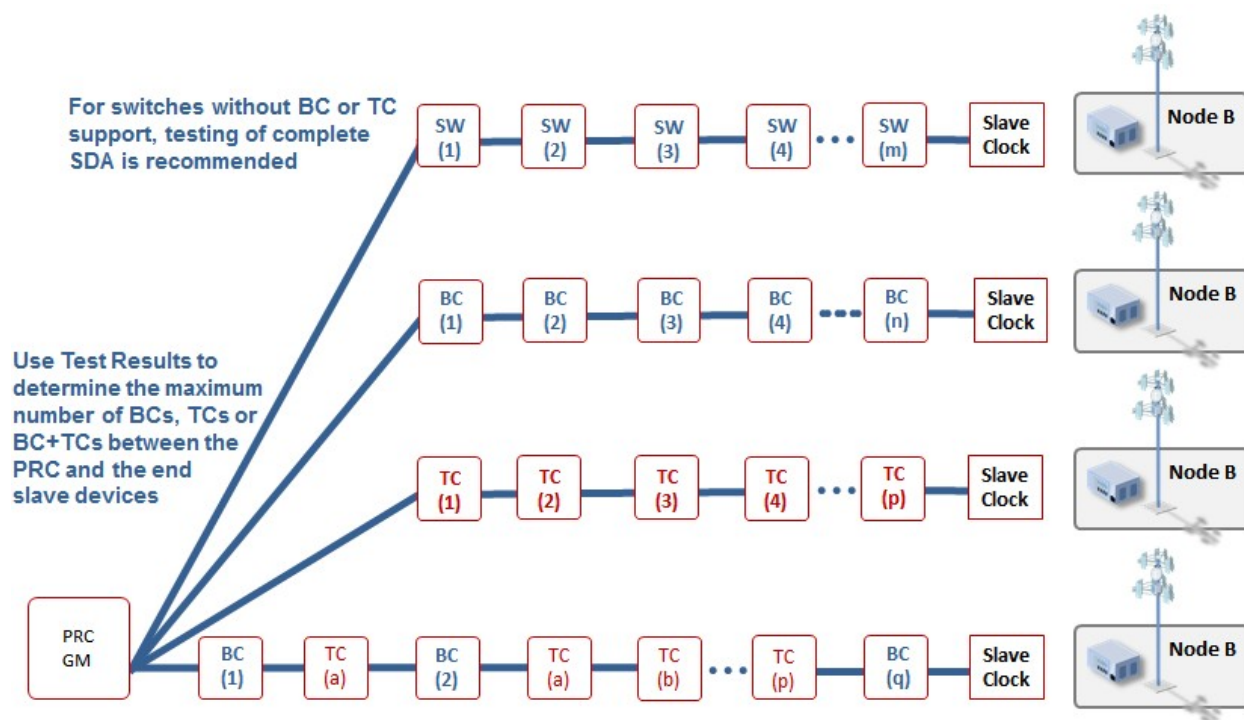

Figure 8 Designing your synchronization distribution architecture

Figure 8 illustrates how test results from a deployed network, as described in Section 3.2, can be used to determine the recommended SDA and hierarchy, including cases where BC and TC are not present in the top row. Test case results are used to determine the maximum number of BCs and TCs that should be used between the PRC grandmaster and end slave clocks.

5 Summary

In conclusion, the IEEE, the ITU-T and the MEF provide mobile backhaul specifications that define packet synchronization distribution backhaul architectures for mobile radio access networks. Many operators are using these guidelines successfully in their networks, including migration paths for packet synchronization. This document supplements MEF22.1 to provide design, testing and deployment insights on synchronization methods.

6 Glossary and Terms

A glossary of terms used in this document can be found online at www.metroethernetforum.org/glossary.

Other terms used in this document

Term	Description
ACR	Adaptive Clock Recovery
BC	Boundary Clock
BITS	Building Integration Time Source
BMC	Base Master Clock

BS	Base Stations
CDMA	Code Division Multiple Access
CE	Customer Edge
DUT	Device Under Test
EEC	Ethernet Equipment Clocks
ESMC	Ethernet Synchronization Messaging Channel
FDD	Frequency Division Duplex
FDR	Frame Delay Range
FDV	Frame Delay Variation
GIWF	Generic Inter-working Function
GM	grandmaster clock
GNSS	Global Navigation Satellite Systems
GPS	Global Positioning System
GSM	Global System for Mobile Communications
LTE	Long Term Evolution
MBMS	Multimedia Broadcast Multicast Service
MEN	Metro Ethernet Network
MIMO	Multiple-Input/Multiple-Output
MTIE	Maximum Time Interval Error
NC	Network Controller
NNI	network node interface
NTP	Network Time Protocol
PDH	Plesiochronous Digital Hierarchy
PDU	protocol data unit
PDV	Packet Delay Variation
ppb	Parts per Billion
ppm	Parts per Million
PRC	Primary Reference Clock
PRMC	Primary Reference Master Clock
PSN	Packet-Switched Network
PTP	Point To Point
QL	Quality Level
RAN	Radio Access Network
SDA	Synchronization Distribution Architecture
SSM	Synchronization Status Messages
SSU	Synchronization Supply Unit
SynchE	Synchronous Ethernet
TC	Transparent Clock
TDD	Time Division Duplex
TDEV	Time deviation
TDM	Time Division Multiplexing
ToD	Time of Day
ToS	Top of Second
UMTS	Universal Mobile Telecommunications Systems
UNI	User Network Interface

7 References

Reference Details
MEF 22.1, "Mobile Backhaul Implementation Agreement Phase 2 Technical Specification"

Reference Details
IEEE 1588™-2008, Standard for a Precision Clock Synchronization Protocol for Networked Measurement and Control Systems.
ITU-T Recommendation G.781 (06/1999), Synchronization layer function
ITU-T Recommendation G.813 (08/1996), Timing Characteristics of SDH equipment slave clocks (SEC)
ITU-T Recommendation G.823 (03/2000), The Control of Jitter and Wander within Digital Networks which are Based on the 2048 kbit/s Hierarchy.
ITU-T Recommendation G.824 (03/2000), The Control of Jitter and Wander within Digital Networks which are Based on the 1544 kbit/s Hierarchy.
ITU-T Recommendation G.8260 (08/2010), Definitions and Terminology for Synchronization in Packet Networks.
ITU-T Recommendation G.8261 (04/2008), Timing and synchronization aspects in packet networks.
ITU-T Recommendation G.8261 Amendment 1 (07/2010), Network Jitter Limits for the Synchronous Ethernet Equipment Clock Interface and Other Clarifications.
ITU-T Recommendation G.8262 (07/2010), Timing characteristics of a Synchronous Ethernet equipment slave clock
ITU-T Recommendation G.8264 (10/2008) Distribution of timing through packet networks
ITU-T Recommendation G.8265 (10/2010), Architecture and Requirements for Packet Based Frequency Delivery.
ITU-T Recommendation G.8265.1 (10/2010), Precision Time Protocol Profile for Frequency Synchronization.
Heavy Reading Ethernet Backhaul Quarterly Tracker, March 2011, Patrick Donegan, www.heavyreading.com
Application Note – Testing 1588v2 (PTP) Transparent Clocks and Boundary Clocks, Calnex Solutions Ltd, 2010
Testing SyncE Wander to ITU-T G.8262, Calnex Solutions Ltd, 201

8 About the MEF

The MEF is an industry Standards Organization with approximately 100 Service providers of a total of 190 member companies and is the industry's defining body for Carrier Ethernet. Defined by five attributes: Standardized Services, Reliability, Quality of Service, Service Management and Scalability Carrier Ethernet has become the service and transport technology of choice for Enterprise business applications and more recently for mobile backhaul applications. In 2011 the MEF celebrated its tenth anniversary and has developed more than 30 technical specifications. More at www.metroethernetforum.org.

9 Acknowledgements

Editor: Charlene Hird, Alcatel-Lucent

Contributors: Anand Ram, Calnex Solutions, Mike Haugh, Ixia

10 Appendix A – Background and Introductory Information

A carrier-class transport network must be able to meet the synchronization requirements of all the services it supports, regardless of the TDM or packet-based technologies it uses to transport and deliver these services. In addition to the technology interfaces already mentioned, a variety of dedicated synchronization interfaces are defined in standards: primary reference clock (PRC), building integrated time source (BITS) (T1, E1, 2 MHz, 6 MHz), one pulse per second (1PPS), and time of day (ToD), as listed in Table 6.

Traffic Interface	Physical Layer	Packet Layer
MEF compliant UNI	SyncE	IEEE 1588v2
TDM	SDH/SONET, PDH	ACR or NTP (MEF8)
Non-traffic interfaces	2MHz, 6MHz, 1PPS, BITS	NTP, ToD

Table 6 Synchronization Technologies and Traffic interfaces

Evolution of Synchronization for Packet Networks

The techniques normally used for synchronization in TDM networks are E1/T1 (PDH), SDH/SONET, GPS and 1PPS+ToD. 2G cell sites are connected to the backhaul network using E1/T1 connectivity. Operators that have embedded TDM networks will maintain some T1/E1s in their network to maintain synchronicity. The same operators can deliver data services over a parallel, asynchronous full packet network. Ethernet connects these 3G/4G cell sites to the packet backhaul network. The operator can then deploy services in hybrid mode, keeping voice traffic on the TDM network and data services on the packet network (evidence of this trend is in the March 2011 Heavy Reading Ethernet Backhaul Quarterly Tracker report), which indicates that T1/E1 line synchronization will remain popular with operators at least through 2013.

Figure 9 illustrates how new IP/Ethernet base stations can be deployed during both the transformation from TDM to packet transport and in hybrid networks, while existing networks continue seamless synchronization of SONET/SDH and Ethernet in mixed domains.

SDH/SONET can provide both transport and synchronization across some parts of an evolving hybrid network, while SyncE provides identical functions in other parts of the same network. This maintains end-to-end synchronization across such networks by supporting both SyncE and SDH/SONET, and seamless interworking between them in any combination for network synchronization.

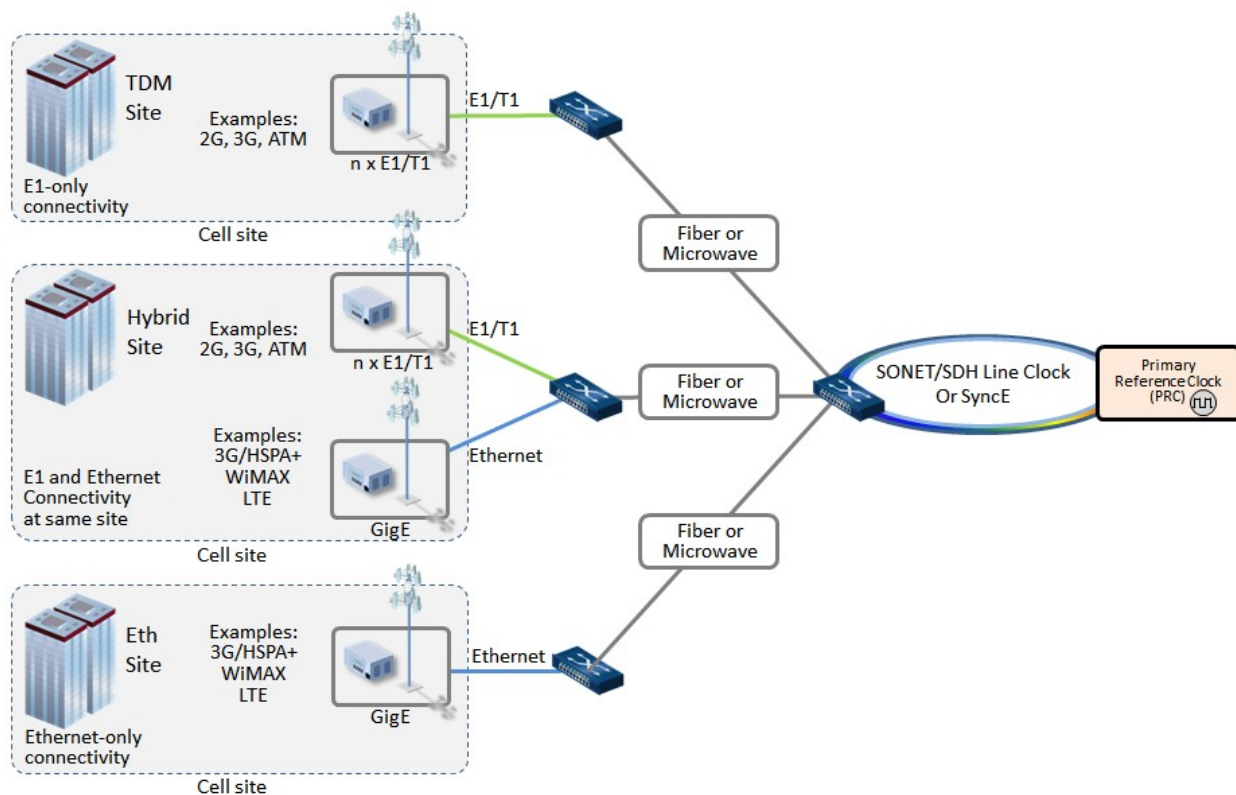

Figure 9 Synchronization Distribution Architecture for TDM and Ethernet Base Stations

Hybrid operators can deploy SyncE and IEEE 1588v2 as they begin to move voice traffic from the TDM to packet-based networks⁵. TDM circuit emulation services (CES)⁶ are transported across packet-based networks. Synchronization is essential to support frequency accuracy and stability. Lack of stability or accuracy will cause bit errors and/or underflows and overflows of frame buffers that result in lost packets in the PDH framing, severely affecting TDM traffic performance.

Figure 10 shows an evolutionary approach to timing options as networks grow and evolve from TDM to packet-based infrastructures. Variety, flexibility, and interoperability of synchronization tools provide options for a smooth evolution.

⁵ NTP is also being used for mobile backhaul

⁶ MEF8

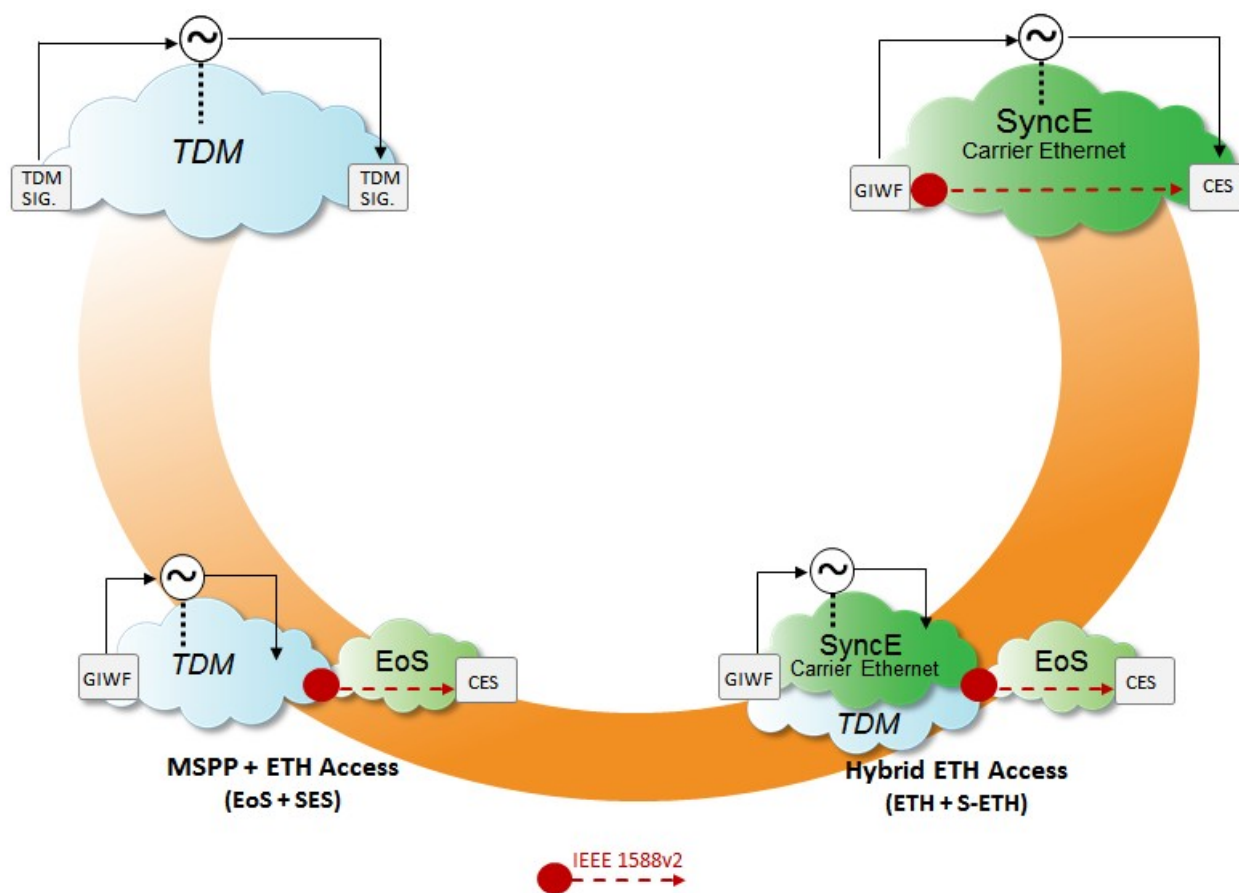

Figure 10 Evolution of Network Timing from TDM to SyncE

As shown in the lower left, interoperability with an Ethernet over SONET (EoS) network requires using TDM circuit emulation service via a CES gateway that acts as a Generic Inter-working Function (GIWF) device. IEEE 1588v2 is required across the EoS cloud to maintain time of day ToD. As SyncE is implemented in the overlay Carrier Ethernet network shown in the lower right, the operator still supports the TDM CES traffic but uses SyncE and IEEE 1588v2. SyncE is used both to recover and distribute frequency at the physical layer in Ethernet-based networks, using the same principles that were developed for synchronization based on SDH/SONET. In the final stage of evolution, shown in the top right, the full packet Carrier Ethernet network supports all traffic, including TDM CES using SyncE and IEEE 1588v2 for ToD.

For operators in a greenfield environment, synchronization evolution is not an issue.. Greenfield deployments use SyncE and IEEE 1588v2 packet synchronization methods on their all-packet networks in order to support voice and data services with TDM-like quality.

10.1 MEF22.1 and Synchronization

Phase 2 of MEF22.1¹, the Mobile Backhaul Implementation Agreement, provides guidelines on synchronization and focus on frequency methods – including how the Carrier Ethernet network

operator can offer a Synchronization Service with a PRC traceable frequency reference towards the Mobile Operator’s Radio Access Network (RAN) BS sites. The focus will be on SyncE and IEEE 1588v2.

MEF22.1 has four use cases that present deployment scenarios for MEF services. Use cases 1a and 1b, shown in Figures 11 and 12, are examples of CES deployments where the RAN BS and RAN Network Controller (NC) cannot be directly connected to a MEF Ethernet UNI.

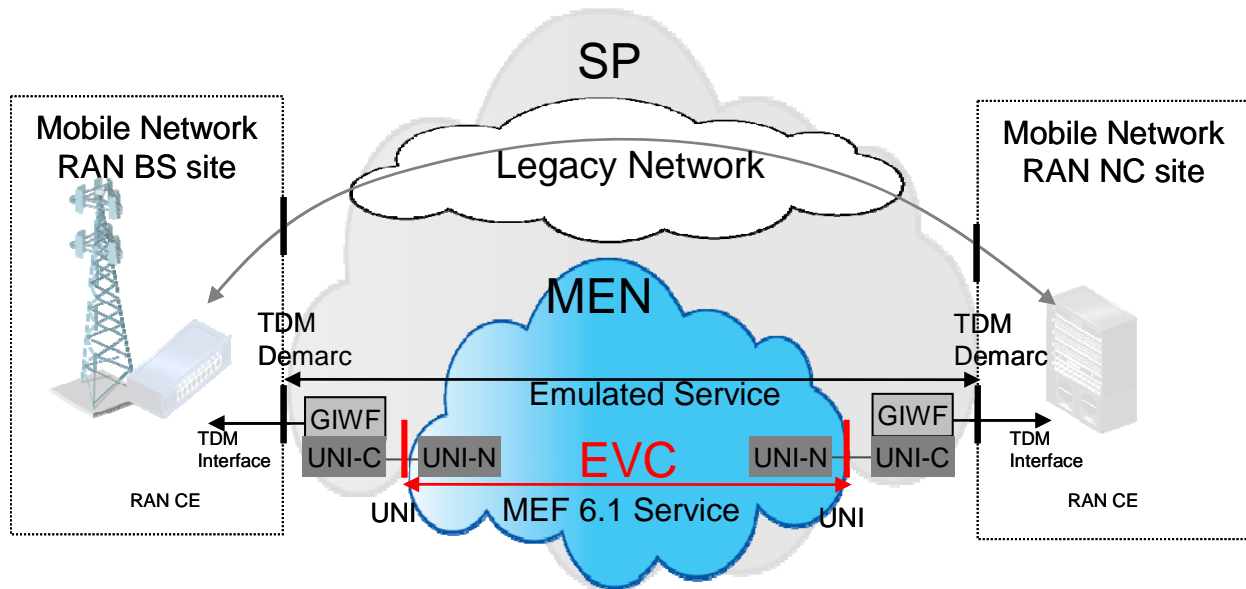

Figure 11 - Use Case 1a - Low Priority traffic with CES across MEN

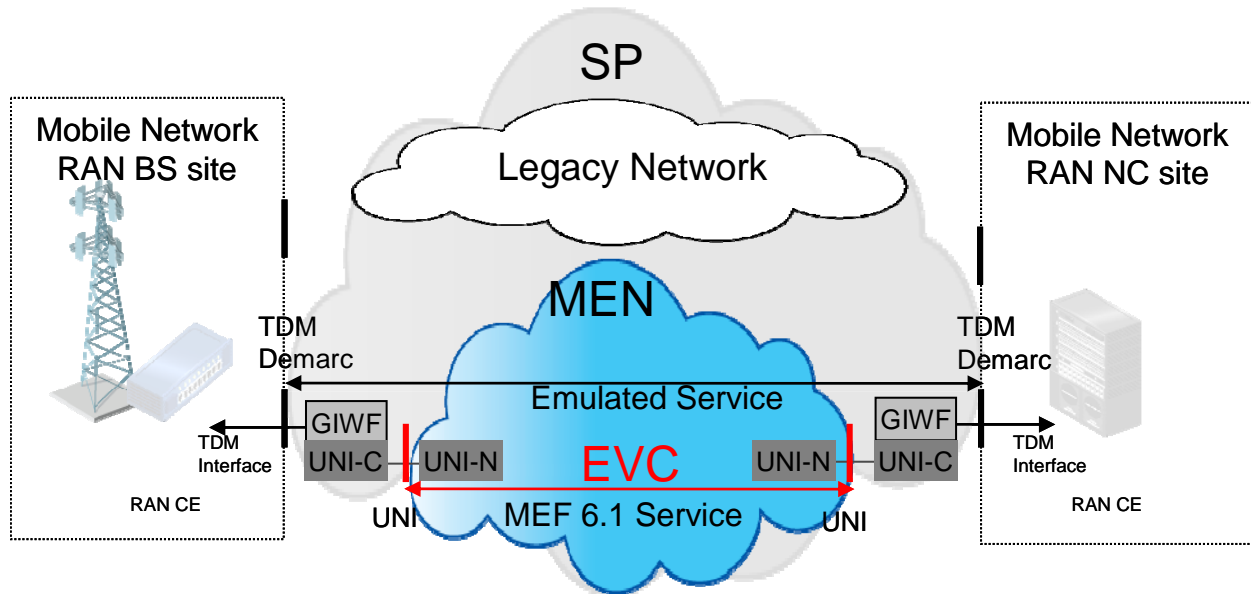

Figure 12 Use Case 1b - All traffic with CES across MEN

Use cases 2a and 2b in Figures 13 and 14 have RAN customer edge (CE) equipment that can be connected directly to the MEN with a MEF compliant UNI-C Ethernet interface, eliminating the need for a GIWF like the CES gateway in Figure 10.

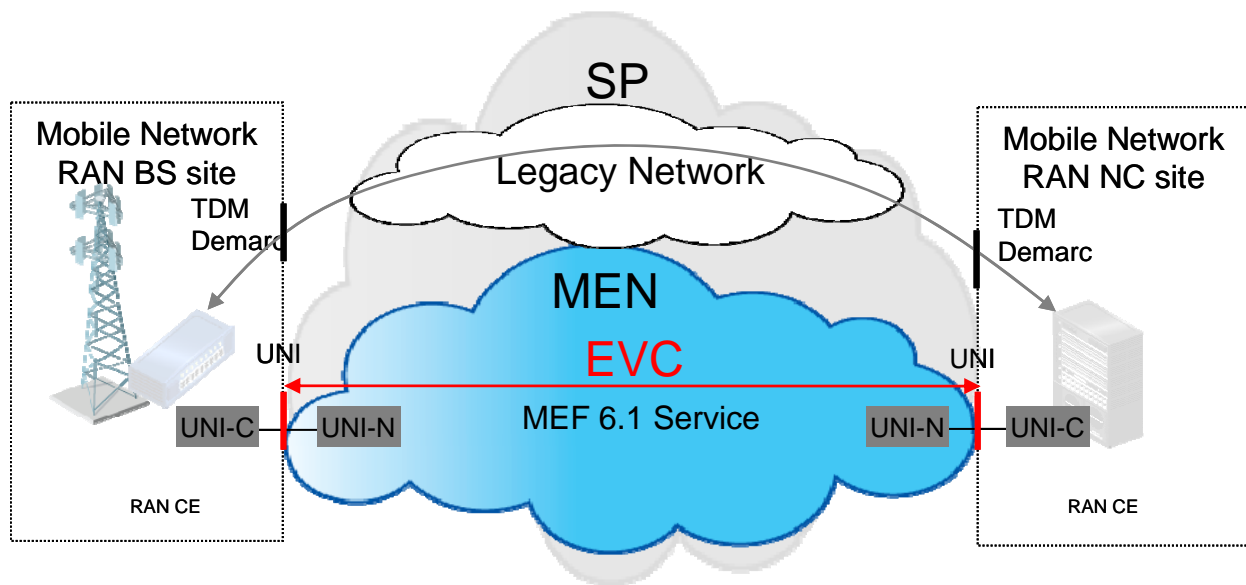

Figure 13 Use case 2a - Low priority traffic with MEF 6.1 Service across MEN

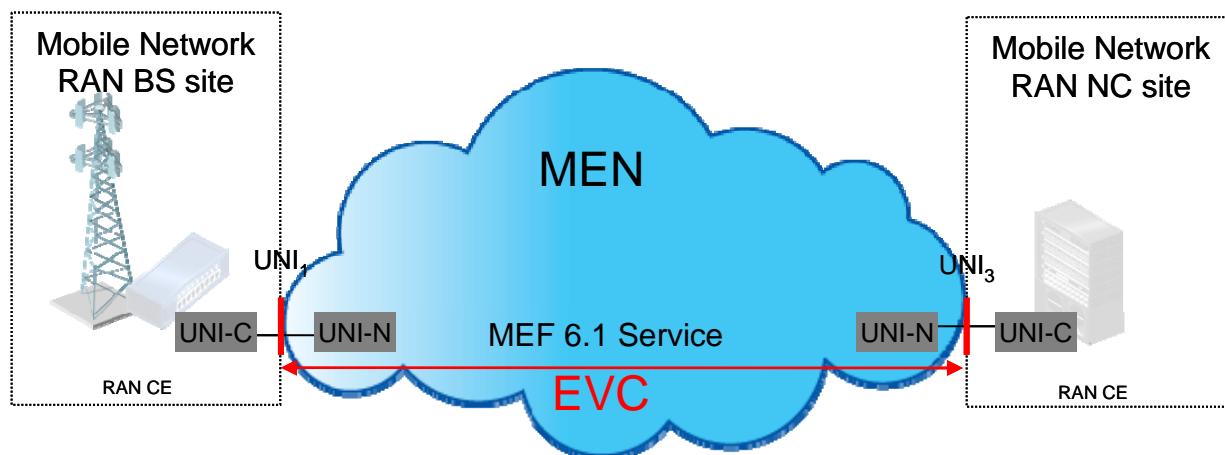

Figure 14 Use case 2b - All traffic with MEF 6.1 Service across MEN

Traffic in use cases 1a and 2a is carried across both legacy and Ethernet networks. In both cases, frequency synchronization is typically recovered from the legacy TDM network.

In use cases 1b and 2b, all services cross the MEN, therefore packet synchronization is needed.

MEF 22.1 Phase 2 recommends performance limits for different Class of Service (CoS) implementations, with Synchronization packets assigned the highest CoS for packet-based technologies, such as IEEE-1588v2. While MEF22.1 will help define performance limits on MEF services as well as interface limits like jitter and wander, for a Mobile Backhaul synchronization distribution architecture, IEEE 1588v2 will have additional performance requirements addressed.

The fundamental issue is that most performance limits today only specify a single limit for Frame Delay or Latency, and a single limit for Frame Delay Variation or Frame Delay Range or Jitter. Clock recovery using IEEE 1588v2 depends not only on the total amount of Delay Variation but more on how the Delay Variation changes. Figure 15 shows two different graphs of FDV over time. In both examples, a Delay Variation maximum limit of 2ms is met. However, the two conditions could affect IEEE 1588v2 clock recovery differently depending on the slave clock algorithm implementation. Clock recovery may be fine under one condition but not the other.

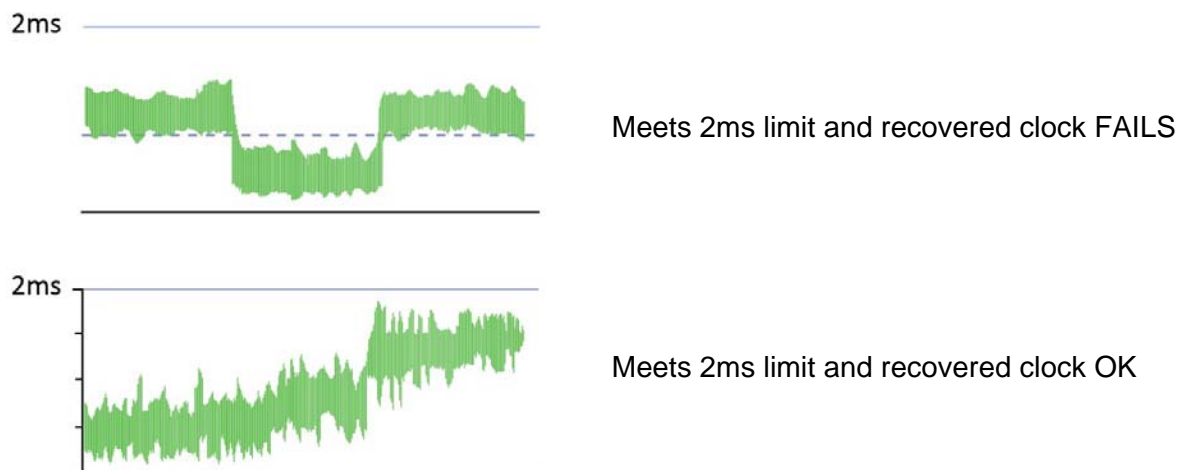

Figure 15 Frame Delay Variation over Time

What is required longer-term is the ability to specify the performance of how FDV changes over time. To this end, the ITU-T Study Group responsible for the ITU-T G.826x packet synchronization recommendations is working on metrics that will be incorporated into the ITU-T G.8260 recommendation. These metrics will specify limits on how the FDV can change over time and address the issue illustrated above.

Once the ITU-T metrics are finalized, they will be incorporated into an evolution of MEF22.1.

11 Appendix B – ITU-T Synchronous Ethernet and the Ethernet Synchronization Messaging Channel (ESMC) Protocol

The purpose of SyncE is to distribute frequency information through an Ethernet device. In this context “frequency” and “bit-rate” effectively have the same meaning, since SyncE determines frequency information from incoming bit streams. The basic operation of SyncE interfaces is to derive frequency from the received bit stream and pass that information up to the system clock. The system clock in a switch or a router is an actual oscillator whose output is used as the clock source for all the SyncE outputs from the device. Most importantly, the output frequency of the transmit interfaces are locked on to the system clock. Ethernet without SyncE interfaces only achieves a frequency accuracy of 100ppm in free-running or holdover conditions, without being locked to a reference. With SyncE interfaces, accuracy is improved to 4.6ppm in free-running or holdover conditions. In normal operation, the SyncE line rate should be frequency-locked to the system master reference, which should deliver parts-per-billion accuracy. It also provides frequency traceability through a network due to the outputs of each device being frequency-locked to the input selected as the master reference.

The basic difference between native Ethernet and SyncE is the PHY transmit clock on the transmit port of the device. In SyncE, the transmit clock must be ± 4.6 ppm accurate in holdover and must be traceable to a Stratum-1 clock via an external Synchronization Supply Unit (SSU)/BITS reference or traceable/locked to the receive clock.

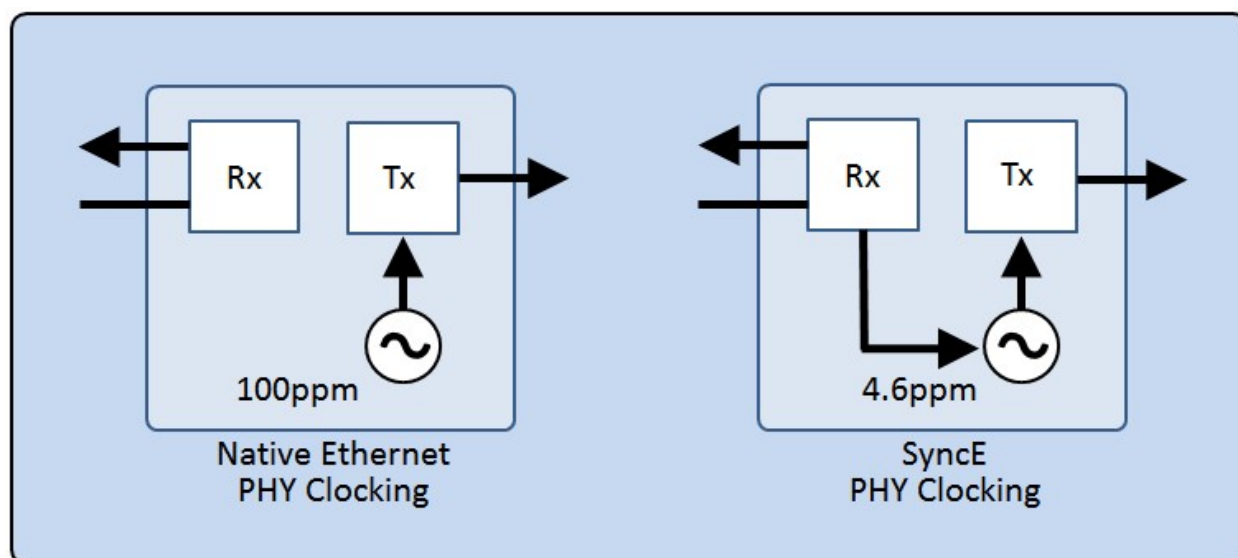

Figure 16 Comparison between two Ethernet PHYs

Figure 16 above shows the difference between native Ethernet and SyncE PHY chips. By enabling the transmit and receive clocks of Ethernet to be linked together, SyncE can be used interchangeably with SONET/SDH. This feature is already common to many high-speed Ethernet chips and is also already available on many ADMs, switches and routers.

While SyncE can distribute frequency, it cannot be used to distribute ToD. SyncE requires upgrading line cards in existing equipment, and potentially changing the clock distribution within the Ethernet Switch device. Requirements for SyncE clocks – also known as Ethernet Equipment Clocks (EEC) – are specified in the ITU-T G.8262 recommendation. SyncE follows the PDH and SONET/SDH telecom examples, where clock information is derived from the incoming bitstream.

The Ethernet Synchronization Messaging Channel (ESMC) protocol is used to transfer information through the synchronization distribution architecture regarding the quality of the synchronisation. ESMC is based on the Organization Specific Slow Protocol (OSSP), which is used in conjunction with SyncE to determine clock selection, clock management, quality traceability, and failover. ESMC uses SSMs of various types to achieve these objectives. SSM messages are sent at a rate of 10 pps (packets per second). ESMC and SSM message formats are defined in ITU-T recommendation G.8264.

A switch in a network receives clocking information in the form of SSM messages from various ingress ports, and the switch must decide which port has the highest quality. SSM messages contain a “quality level” for exactly that purpose. The algorithm selects the ingress port with the highest quality clock and designates it as the reference clock.

As with the basic clock extraction method, SSM messages in SyncE are derived much like their counterparts in the SONET and SDH telecom worlds and provide two options for interworking. EEC-Option 1 is optimized for hierarchy based on 2048 kb/s (commonly referred to as E1), and EEC-Option 2 is optimized for a hierarchy based on 1544 kb/s (commonly referred to as T1).

SSM messages are broadly grouped into two types: events and information. All messages contain the quality level (QL) field. A single bit, the event flag, is used to distinguish event protocol data units (PDU) from information PDUs. Event PDUs are sent when there is a change in the quality level.

The structure of SSM messages is shown in Table 7 below:

Table 7 SSM Message Structure

Octets	Size	Field Description
1-6	6 octets	Destination address = 01-80-C2-00-00-02 (hex)
7-12	6 octets	Source address
13-14	2 octets	Slow protocol Ethertype = 88-09 (hex)
15	1 octet	Slow protocol subtype = 0A (hex)
16-18	3 octets	ITU-OUI = 00-19-A7 (hex)
19-20	2 octets	ITU Subtype
21	4 bits	Version
	1 bit	Event flag
	3 bits	Reserved
22-24	3 octets	Reserved
25-28	4 octets	QL-TLV (type, length, reserve, SSM)
29-1532	32-1486 octets	Future enhancement TLVs and padding
Last 4	4 octets	FCS

The selection mechanism is based on QLs and results in a hierarchy of masters and slaves, with all clocking in a network traceable to a primary reference clock. Figure 17 below shows a simple example of such a master/slave network as outlined in ITU-T G.8261.

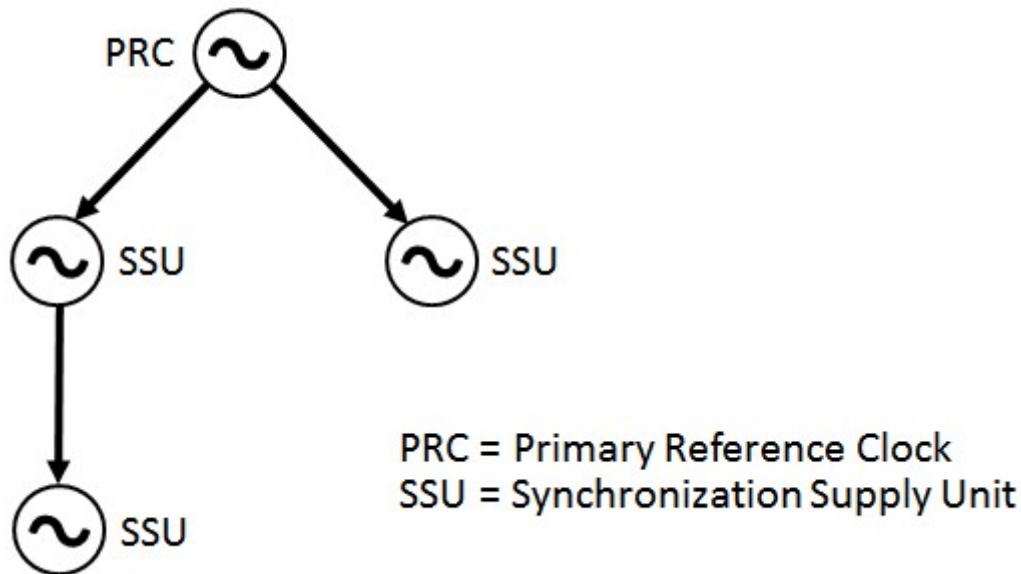

Figure 17 ITU-T G.8261 Master/Slave Network Example

Note that an alternate architecture such as GPS can be used to distribute primary reference clocks to each device in the network, however these can be more costly than either SyncE or packet-based approaches like IEEE 1588v2.

12 Appendix C - IEEE 1588v2, the Precision Timing Protocol

The IEEE 1588-2008 (referred to as 1588v2) standard specifies the Precision Timing Protocol (PTP) for network synchronization. PTP uniquely solves all three frequency, phase, and time-of-day distribution synchronization problems. PTP was introduced to overcome the poor accuracy available with traditional software-based NTP implementations, and the feasibility limitations associated with GPS technology. Being a packet-based solution, PTP is susceptible to packet-based impairments such as PDV. PTP exists for both unicast and multicast applications.

A second version of the IEEE-1588 standard (informally known as 1588v2) was finalized in 2008 to include the following key enhancements:

- **Addition of transparent clocks.** Transparent clocks improve synchronization accuracy between slave and master clocks in a synchronization distribution architecture. As the name implies, transparent clocks are invisible to the clocks immediately upstream and downstream. Timing transparency is achieved in transparent clocks by modifying the Delay_Resp, Sync, and/or Follow-up messages as they transit through a switch to account for the receive and transmit delays through a device.
- **Shorter sync messages.** The first version of the specification used sync messages which were 165 bytes long. Version 2 shortened sync messages to 44 bytes in order to speed up processing, and broke out some of the functionality into separate Announce messages for use in establishing hierarchy.

- **Varied (faster) update rates.** This change goes hand-in-hand with the shorter sync message change to the specification. Shorter messages are easier to process, and therefore can be sent more frequently without overloading processors. The original spec sent messages at a rate of once every 30 seconds, while version 2 sends messages up to 256 times per second.
- **Layer 2 transport option.** The messages listed in Table 8 and Table 9 below are deliberately not described as “frames” or “packets” because IEEE 1588 allows transport of these messages using a number of underlying technologies. Within telecom networks, IEEE 1588 messages will likely be used over UDP/IP, but the IEEE 1588 specification also supports messaging directly over Ethernet and Ethernet-based technologies for industrial applications such as factory automation.
- **Unicast transport option.** The original IEEE 1588 specification was targeted more at industrial applications, which mapped to multicast IP technology. However, for telecom wireless backhaul applications, unicast is required to optimize network performance. The second version of the IEEE 1588 specification includes support for unicast by allowing receiving ports to optionally request upstream ports that Announce, Sync, Delay_Resp and Pdelay_Resp messages be sent over unicast rather than multicast.
- **Fault tolerance support.** IEEE 1588v2 allows for an occasional missed message, and does not interpret a missed message as needing a dramatic change to the clocking hierarchy.
- **Rapid reconfiguration in response to network changes.** When a clock fails, PTP automatically reconfigures the network. Similar to the concept of spanning trees, the clocking hierarchy is an overlay of a loop-free tree on top of more connected (e.g. mesh) topology. If a clock fails somewhere in the hierarchy, the clocking topology can reconfigure itself to a new, loop-free topology.

Unlike SyncE, which derives its clocking information from the incoming bitstream, IEEE 1588v2 is a purely packet-based solution, with the actual clock values being passed inside the payloads of special packets dedicated to that task. The packets or messages sent by PTP are classified broadly into either event messages or general messages.

There are four specific event messages as shown in Table 8, and five types of general messages, shown in Table 9.

Table 8 PTP Event Message Types

<i>Event Message Type</i>	<i>Purpose</i>
Sync	Used to generate and communicate timing information
Delay_Req	

Pdelay_Req	Used to measure delay information between two ports
Pdelay_Resp	

Table 9 PTP General Message Types

General Message Type	Purpose
Announce	Used to establish synchronization hierarchy
Follow-up	Used to generate and communicate timing information
Delay_Resp	
Pdelay_Resp	Used to measure delay information between two ports
Management	Used to query and update datasets
Signaling	Used for all other purposes, e.g. rate negotiation

IEEE 1588v2 establishes a master-slave hierarchy of clocks in a synchronization distribution architecture, with all clocks ultimately synchronized to a grandmaster clock acting as the primary time source. The “Announce” messages are used to establish a hierarchy. IEEE1588v2 also separates networks into regions, with one master clock per region used as the primary time source for all clocks in that region.

IEEE 588v2 defines four types of clocks, and one additional device type:

- Ordinary clock: a PTP clock with only one PTP port
- Boundary clock: a PTP clock with more than one PTP port that acts as both a master and slave clock
- Transparent clock: a PTP clock that forwards all messages and adjusts them to reflect the residency time associated with the Sync and Delay_Req as they pass through the device. The delays are inserted in the Correction Field.
- Management node: a PTP device with multiple ports and a human or programmatic interface

Clocks can implement End-to-End or Peer-to-Peer Delay mechanisms. End-to-end clocks measure and utilise the end-to-end delays while for peer-to-peer, the delay is measured section by section of the clock path.

All clocks in a synchronization distribution architecture are either boundary or ordinary clocks. Figure 18 below shows a IEEE 1588v2 network with master and slave ordinary clocks and boundary clocks.

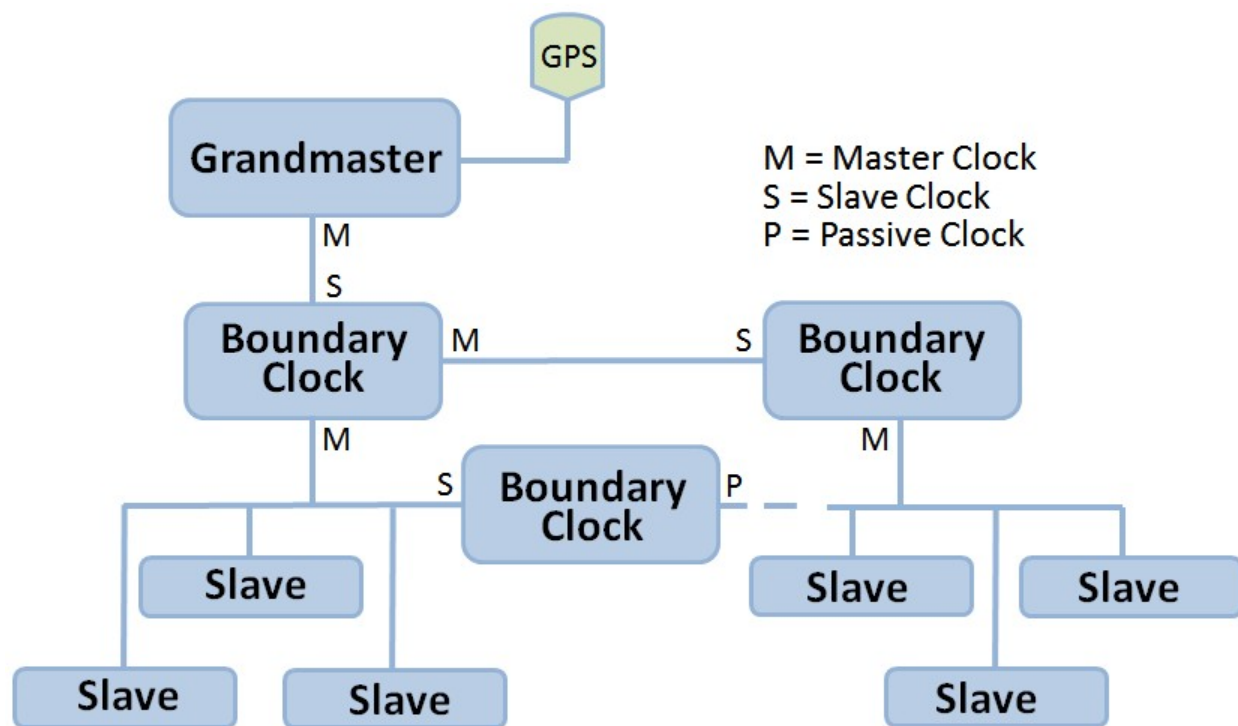

Figure 18 IEEE 1588v2 Clock Hierarchy

IEEE 1588v2 uses the “Best Master Clock” algorithm to select the best clock. The algorithm compares data sets associated with each candidate clock. The algorithm attempts to choose a clock from a better grandmaster, taking into account such things as traceability, number of steps removed, and the quality of the grandmaster clock.

Besides establishing the master-slave hierarchy, the other primary task of PTP is to synchronize the clocks throughout the synchronization distribution architecture. The basic challenge is that across each link, packets experience some delay, all of which must be used to adjust the clock’s value as it is propagated through the network.

To determine delay information, IEEE 1588v2 uses a simple technique to effectively calculate the one-way transit time of simple stimulus and response, and then assumes that the network delays are symmetric in order to calculate the transit time through the device. The transient delay, once determined, is then added to the ingress clock value for the outgoing clock value.

A boundary clock can perform both the slave and master function. The IEEE 1588v2 message flow is terminated and the frequency and/or time recovered from the ingress messages. This is

used to guide its internal reference. The boundary clock then acts as the master to the downstream clock by generating a new 1588v2 message flow using timestamps generated from its internal reference.

Appendix D – IEEE 1588v2 Transparent Clock and Boundary Clock Tests evaluates how to test functionality and performance of IEEE 1588v2 Transparent Clocks and Boundary Clocks, items currently being studied by the ITU-T Study Group 15 (Question 13).

Appendix D – IEEE 1588v2 Transparent Clock and Boundary Clock Tests

The evaluation of the functionality and performance of Transparent Clocks (TC) and Boundary Clocks (BC) are currently being studied by the ITU-T Study Group 15 (Question 13). The tests below are suggestions for high level approaches that can be taken to evaluate TCs and BCs. They form the basis of proposals currently being discussed in the ITU-T Study Group.

Transparent Clock Testing

A TC measures and timestamps the delay within itself, adding this value to the Correction Field in the IEEE 1588v2 packet as shown in Figure 19 below. The idea is that a slave device will have the delay information of all the TC nodes that the timing packet has passed through and therefore will have information about the PDV and be able to remove this PDV from its calculation and recover the time more easily.

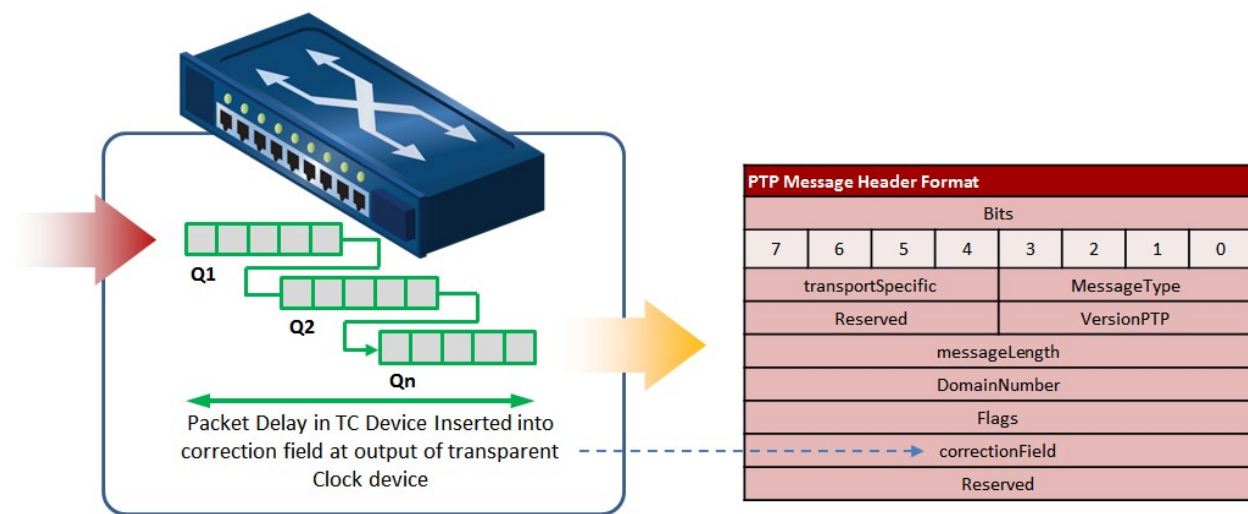

Figure 19 Packet Delay in TC

In order to test the performance of a TC, the test setup shown in Figure 20 is used. This evaluates the accuracy of the correction factors inserted by the TCs. The PDV Meter is used to evaluate the PDV and the measured PDV in Forward and Reverse directions. Traffic loading should be close to zero when the Correction Field is used in the calculation.

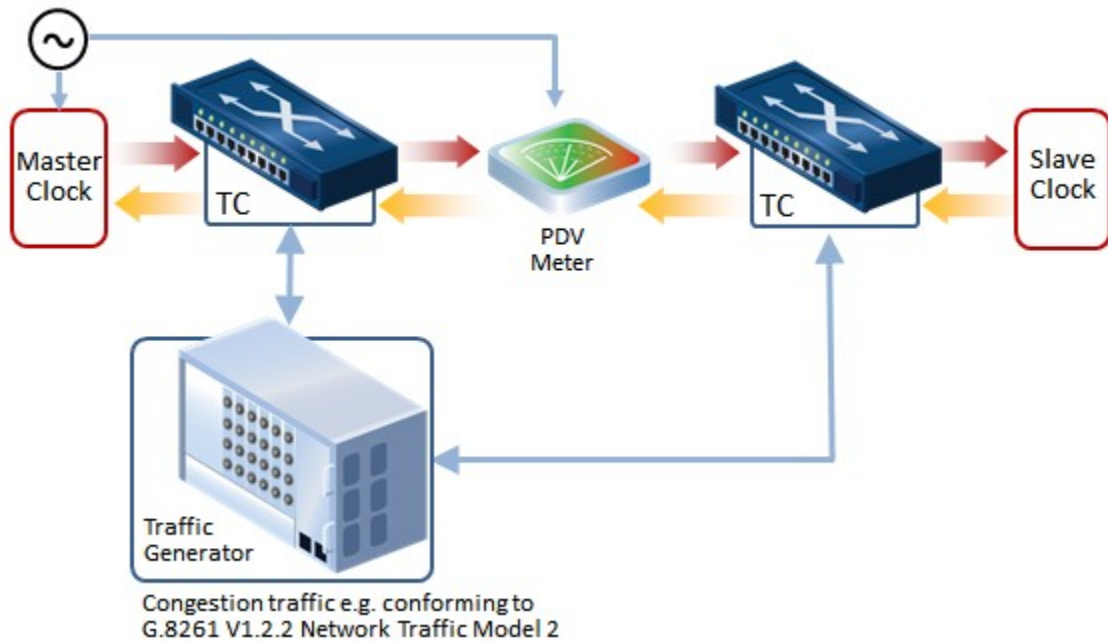

Figure 20 Congestion Traffic Test Set-up

An alternative test setup is shown in Figure 21 where the error of the TC Correction Field is measured.

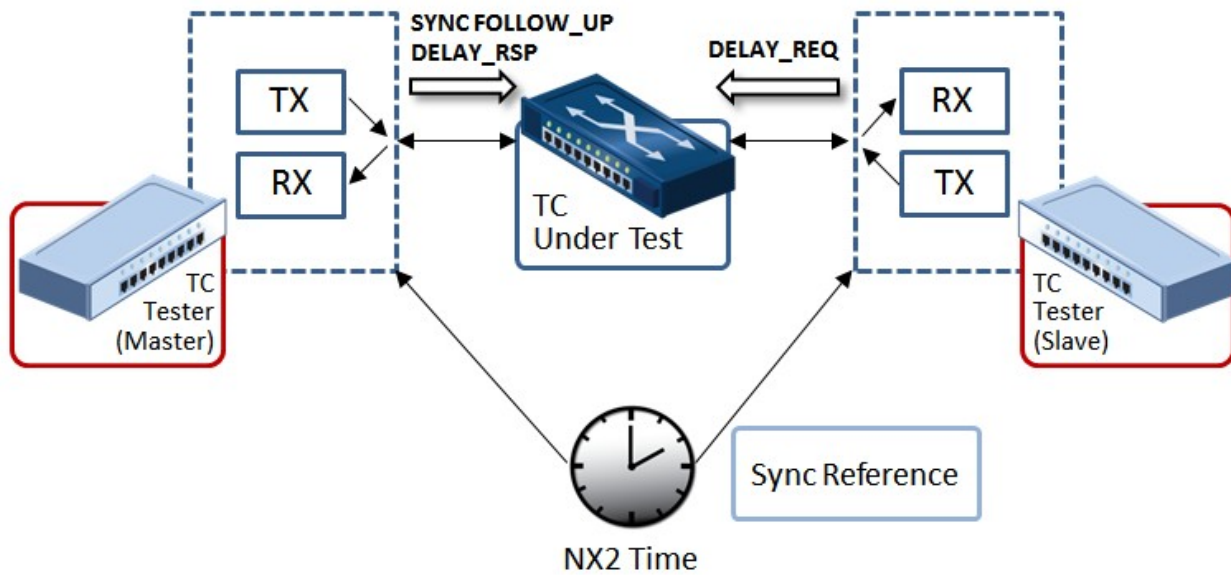

Figure 21 TC Test Configuration

Boundary Clock Testing

A BC is effectively a node that recovers timing from the incoming IEEE 1588v2 as a slave and then uses this recovered timing to re-time the outgoing signal. It then acts as the IEEE 1588v2 Master for the next node. By using this mechanism, the impact of PDV is minimized as the packets will not travel through many routers or switches between Master and Slave.

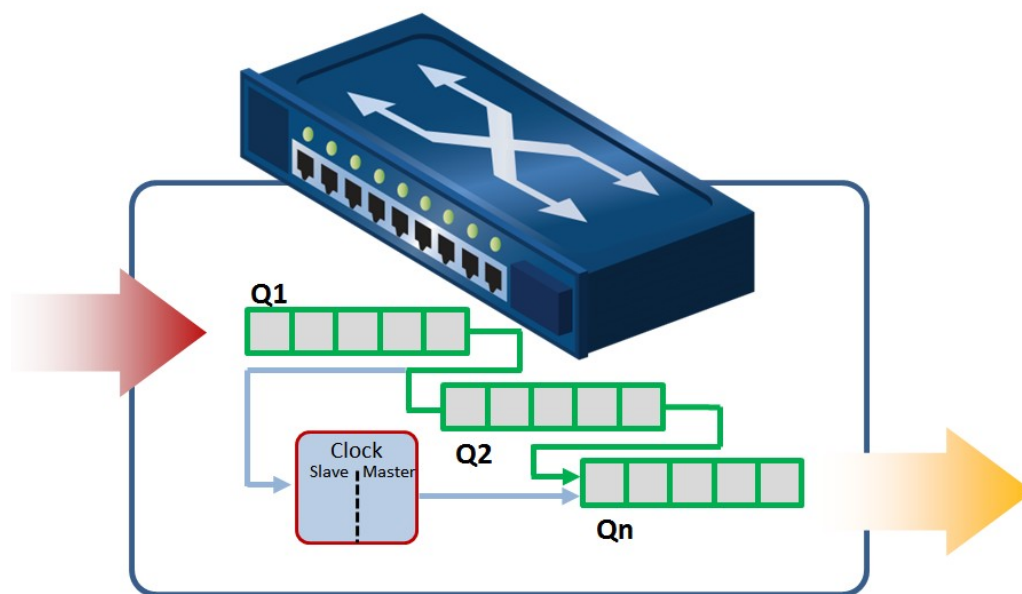

Figure 22 Boundary Clock

Boundary Clocks are tested in two ways. First, the PDV performance of a single node has to be measured and shown to be minimal. This is done using the test setup shown in

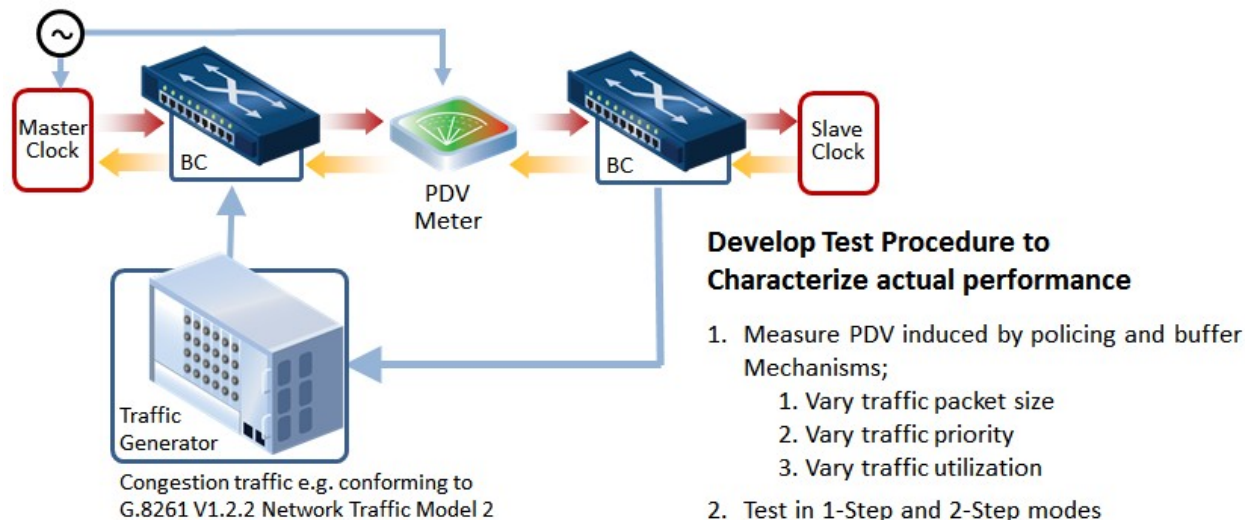

Figure 23.

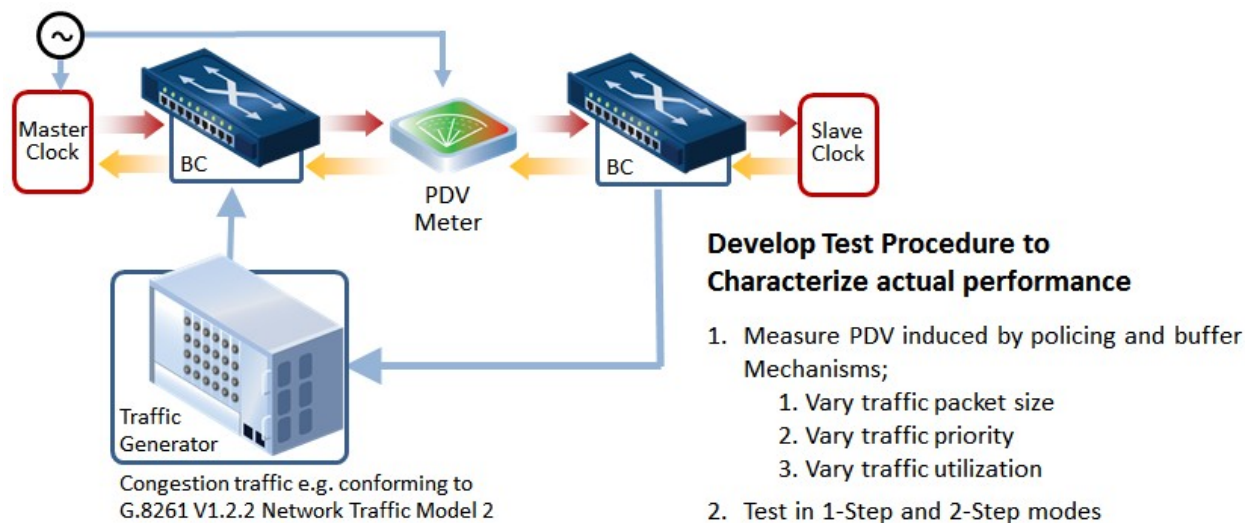

Figure 23 Development Test Procedure

A second category of tests addresses when BCs are deployed in a network. They will function like nodes in a TDM network, recovering the clock and re-clocking at every node. The tests, therefore, are similar to the tests for TDM Nodes as shown in Figure 24. These tests evaluate Wander output, accumulation and tolerance to make sure there will not be excessive clock inaccuracy when deployed. It should be noted that the test setups and test cases for TCs and BCs are under study at the ITU-T Study Group 15 (Question 13).

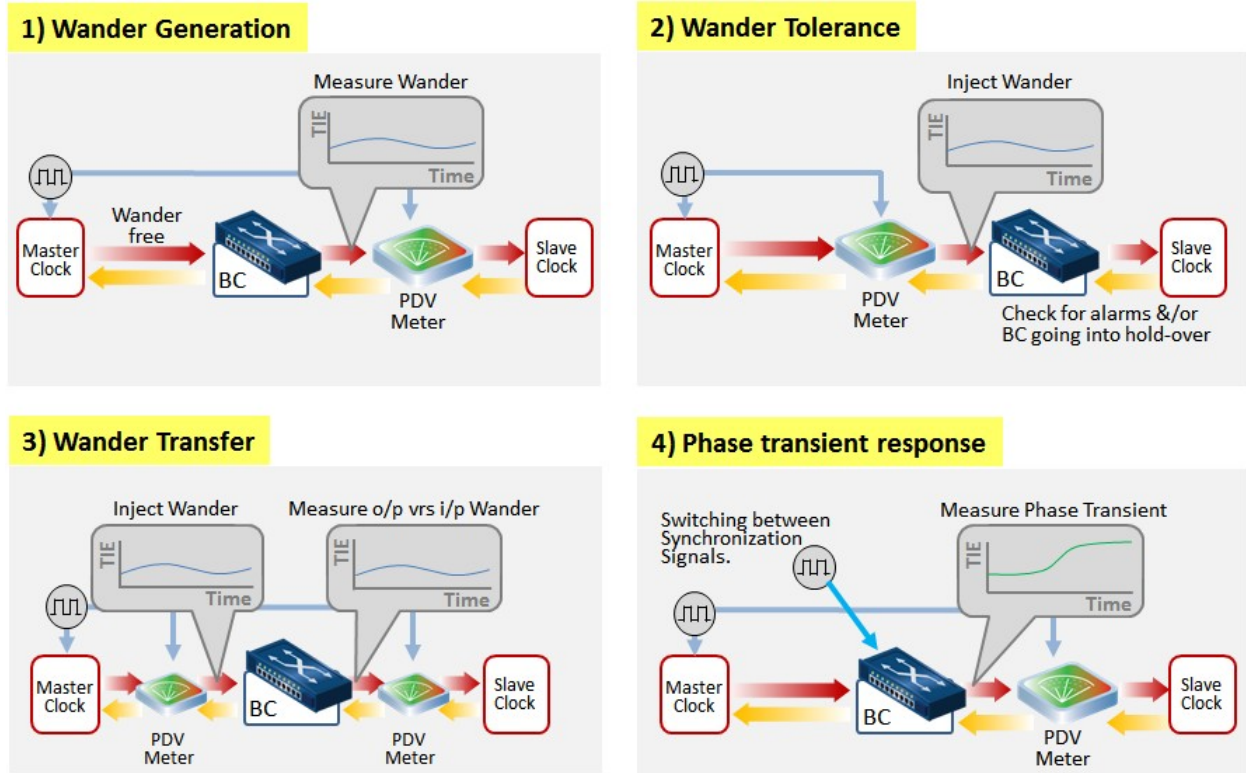

Figure 24 Boundary Clock Wander Tests