

## LM74

### SPI/MICROWIRE™ Digital Temperature Sensor

#### General Description

The LM74 is a temperature sensor, Delta-Sigma analog-to-digital converter with an SPI and MICROWIRE compatible interface. The host can query the LM74 at any time to read temperature. A shutdown mode decreases power consumption to less than 10  $\mu\text{A}$ . This mode is useful in systems where low average power consumption is critical.

The LM74 has 12-bit plus sign temperature resolution (0.0625°C per LSB) while operating over a temperature range of -55°C to +150°C.

The LM74's 3.0V to 5.5V supply voltage range, low supply current and simple SPI interface make it ideal for a wide range of applications. These include thermal management and protection applications in hard disk drives, printers, electronic test equipment, and office electronics.

#### Applications

- System Thermal Management
- Personal Computers
- Disk Drives
- Office Electronics

- Electronic Test Equipment

#### Features

- 0.0625°C temperature resolution.
- Shutdown mode conserves power between temperature reading
- SPI and MICROWIRE Bus interface
- SO-8 package saves space

#### Key Specifications

■ Supply Voltage		3.0V to 5.5V
■ Supply Current	operating	310 $\mu\text{A}$ (typ) 520 $\mu\text{A}$ (max)
	shutdown	7 $\mu\text{A}$ (typ)
■ Temperature Accuracy	-10°C to 65°C	$\pm 1.25^\circ\text{C}$ (max)
	-25°C to 110°C	$\pm 2.1^\circ\text{C}$ (max)
	-55°C to 125°C	$\pm 3^\circ\text{C}$ (max)

#### Simplified Block Diagram

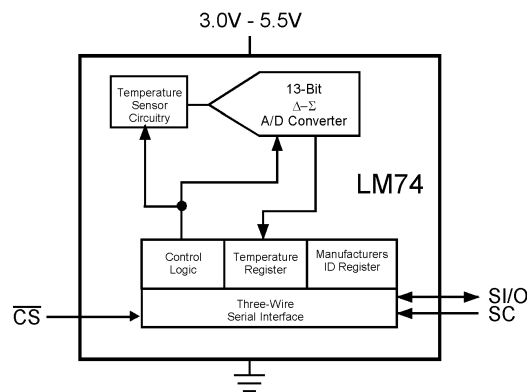

DS100909-1

MICROWIRE® is a registered trademark of National Semiconductor Corporation.

## Connection Diagram

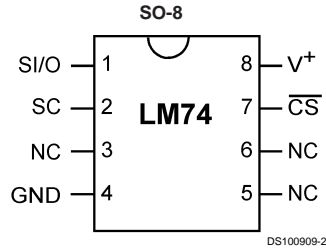

TOP VIEW  
NS Package Number M08B

## Ordering Information

Order Number	NS Package Number	Supply Voltage	Transport Media
LM74CIM-3	SO-8, M08B	3.0V to 3.6V	95 Units in Rail
LM74CIMX-3	SO-8, M08B	3.0V to 3.6V	2500 Units in Tape and Reel
LM74CIM-5	SO-8, M08B	4.5V to 5.5V	95 Units in Rail
LM74CIMX-5	SO-8, M08B	4.5V to 5.5V	2500 Units in Tape and Reel

## Pin Descriptions

Label	Pin #	Function	Typical Connection
S/I/O	1	Slave Input/Output - Serial bus bi-directional data line. Shmitt trigger input.	From and to Controller
SC	2	Slave Clock - Serial bus clock Shmitt trigger input line.	From Controller
NC	3	No Connection	No Connection
GND	4	Power Supply Ground	Ground
NC	5	No Connection	No Connection
NC	6	No Connection	No Connection
$\overline{\text{CS}}$	7	Chip Select input.	From Controller
V <sup>+</sup>	8	Positive Supply Voltage Input	DC Voltage from 3.0V to 5.5V. Bypass with a 0.1 $\mu\text{F}$ ceramic capacitor.

**Typical Application**

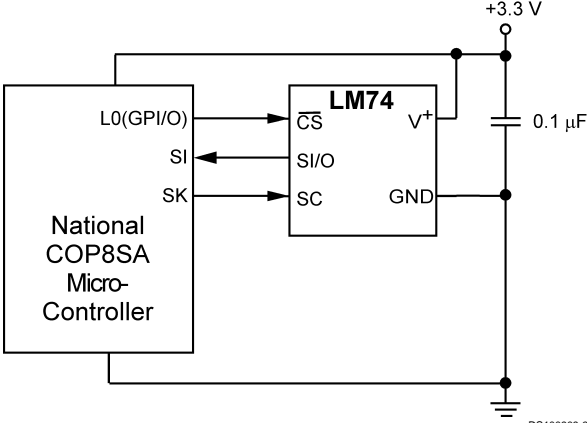

**FIGURE 1. COP Microcontroller Interface**

DS100909-3

## Absolute Maximum Ratings (Note 1)

Supply Voltage	-0.3V to 6.0V
Voltage at any Pin	-0.3V to V <sup>+</sup> + 0.3V
Input Current at any Pin (Note 2)	5 mA
Package Input Current (Note 2)	20 mA
Storage Temperature	-65°C to +150°C
Soldering Information, Lead Temperature	
SOP Package (Note 3)	
Vapor Phase (60 seconds)	215°C
Infrared (15 seconds)	220°C

## ESD Susceptibility (Note 4)

Human Body Model	2000V
Machine Model	200V

## Operating Ratings

Specified Temperature Range (Note 5)	T <sub>MIN</sub> to T <sub>MAX</sub> -55°C to +150°C
Supply Voltage Range (+V <sub>S</sub> )	+3.0V to +5.5V

## Temperature-to-Digital Converter Characteristics

Unless otherwise noted, these specifications apply for V<sup>+</sup> = 3.0V to 3.6V for the LM74CIM-3 and V<sup>+</sup> = 4.5V to 5.5V for the LM74CIM-5 (Note 6). **Boldface limits apply for T<sub>A</sub> = T<sub>J</sub> = T<sub>MIN</sub> to T<sub>MAX</sub>**; all other limits T<sub>A</sub> = T<sub>J</sub> = +25°C, unless otherwise noted.

Parameter	Conditions	Typical (Note 7)	LM74-5 Limits (Note 8)	LM74-3 Limits (Note 8)	Units (Limit)
Temperature Error (Note 6)	T <sub>A</sub> = -10°C to +65°C		<b>±1.25</b>	<b>±1.25</b>	°C (max)
	T <sub>A</sub> = -25°C to +110°C		<b>±2.1</b>	<b>+2.65/-2.15</b>	°C (max)
	T <sub>A</sub> = -40°C to +85°C		<b>+2.65/-1.65</b>	<b>±2.15</b>	°C (max)
	T <sub>A</sub> = -40°C to +110°C		<b>+2.65/-2.0</b>	<b>+2.65/-2.15</b>	°C (max)
	T <sub>A</sub> = -55°C to +125°C		<b>±3.0</b>	<b>±3.5</b>	°C (max)
	T <sub>A</sub> = -55°C to +150°C		<b>±5.0</b>	<b>±5.0</b>	°C (max)
Resolution		13			Bits
Temperature Conversion Time	(Note 9)	280	<b>425</b>	<b>425</b>	ms (max)
Quiescent Current	Serial Bus Inactive	310	<b>520</b>	<b>520</b>	µA (max)
	Serial Bus Active	310			µA
	Shutdown Mode, V <sup>+</sup> = 3.3V	7			µA
	Shutdown Mode, V <sup>+</sup> = 5V	8			µA

## Logic Electrical Characteristics

### DIGITAL DC CHARACTERISTICS

Unless otherwise noted, these specifications apply for V<sup>+</sup> = 3.0V to 3.6V for the LM74CIM-3 and V<sup>+</sup> = 4.5V to 5.5V for the LM74CIM-5. **Boldface limits apply for T<sub>A</sub> = T<sub>J</sub> = T<sub>MIN</sub> to T<sub>MAX</sub>**; all other limits T<sub>A</sub> = T<sub>J</sub> = +25°C, unless otherwise noted.

Symbol	Parameter	Conditions	Typical (Note 7)	Limits (Note 8)	Units (Limit)
V <sub>IN(1)</sub>	Logical "1" Input Voltage			<b>V<sup>+</sup> x 0.7</b>	V (min)
				<b>V<sup>+</sup> + 0.3</b>	V (max)
V <sub>IN(0)</sub>	Logical "0" Input Voltage			<b>-0.3</b>	V (min)
				<b>V<sup>+</sup> x 0.3</b>	V (max)
	Input Hysteresis Voltage	V <sup>+</sup> = 3.0V to 3.6V	0.8	<b>0.35</b>	V (min)
		V <sup>+</sup> = 4.5V to 5.5V	0.8	<b>0.33</b>	V (min)
I <sub>IN(1)</sub>	Logical "1" Input Current	V <sub>IN</sub> = V <sup>+</sup>	0.005	<b>3.0</b>	µA (max)
I <sub>IN(0)</sub>	Logical "0" Input Current	V <sub>IN</sub> = 0V	-0.005	<b>-3.0</b>	µA (min)
C <sub>IN</sub>	All Digital Inputs		20		pF
V <sub>OH</sub>	High Level Output Voltage	I <sub>OH</sub> = -400 µA		<b>2.4</b>	V (min)
V <sub>OL</sub>	Low Level Output Voltage	I <sub>OL</sub> = +2 mA		<b>0.4</b>	V (max)
I <sub>O_TRI-STATE</sub>	TRI-STATE Output Leakage Current	V <sub>O</sub> = GND		<b>-1</b>	µA (min)
		V <sub>O</sub> = V <sup>+</sup>		<b>+1</b>	µA(max)

## Logic Electrical Characteristics (Continued)

### SERIAL BUS DIGITAL SWITCHING CHARACTERISTICS

Unless otherwise noted, these specifications apply for  $V^+ = 3.0V$  to  $3.6V$  for the LM74CIM-3 and  $V^+ = 4.5V$  to  $5.5V$  for the LM74CIM-5,  $C_L$  (load capacitance) on output lines =  $100\text{ pF}$  unless otherwise specified. **Boldface limits apply for  $T_A = T_J = T_{MIN}$  to  $T_{MAX}$** ; all other limits  $T_A = T_J = +25^\circ\text{C}$ , unless otherwise noted.

Symbol	Parameter	Conditions	Typical (Note 7)	Limits (Note 8)	Units (Limit)
$t_1$	SC (Clock) Period			<b>0.33</b> DC	$\mu\text{s}$ (min) (max)
$t_2$	$\overline{\text{CS}}$ Low to SC (Clock) High Set-Up Time			<b>100</b>	ns (max)
$t_3$	$\overline{\text{CS}}$ Low to Data Out (SO) Delay			<b>70</b>	ns (max)
$t_4$	SC (Clock) Low to Data Out (SO) Delay			<b>100</b>	ns (max)
$t_5$	$\overline{\text{CS}}$ High to Data Out (SO) TRI-STATE			<b>200</b>	ns (min)
$t_6$	SC (Clock) High to Data In (SI) Hold Time			<b>50</b>	ns (min)
$t_7$	Data In (SI) Set-Up Time to SC (Clock) High			<b>30</b>	ns (min)

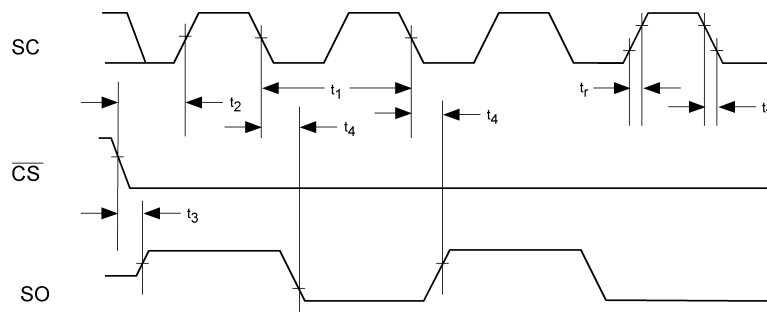

DS100909-4

FIGURE 2. Data Output Timing Diagram

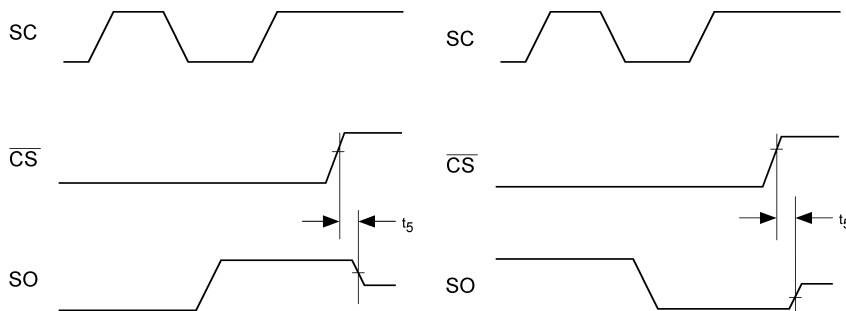

DS100909-5

FIGURE 3. TRI-STATE Data Output Timing Diagram

## Logic Electrical Characteristics (Continued)

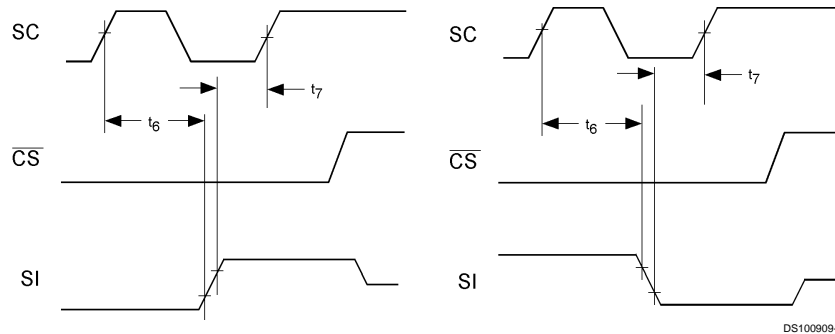

FIGURE 4. Data Input Timing Diagram

**Note 1:** Absolute Maximum Ratings indicate limits beyond which damage to the device may occur. DC and AC electrical specifications do not apply when operating the device beyond its rated operating conditions.

**Note 2:** When the input voltage ( $V_I$ ) at any pin exceeds the power supplies ( $V_I < \text{GND}$  or  $V_I > +V_S$ ) the current at that pin should be limited to 5 mA. The 20 mA maximum package input current rating limits the number of pins that can safely exceed the power supplies with an input current of 5 mA to four.

**Note 3:** See AN-450 "Surface Mounting Methods and Their Effect on Product Reliability" or the section titled "Surface Mount" found in a current National Semiconductor Linear Data Book for other methods of soldering surface mount devices.

**Note 4:** Human body model, 100 pF discharged through a 1.5 k $\Omega$  resistor. Machine model, 200 pF discharged directly into each pin.

**Note 5:** The life expectancy of the LM74 will be reduced when operating at elevated temperatures. LM74  $\theta_{JA}$  (thermal resistance, junction-to-ambient) when attached to a printed circuit board with 2 oz. foil is summarized in the table below:

Device Number	NS Package Number	Thermal Resistance ( $\theta_{JA}$ )
LM74CIM	M08B	160°C/W

**Note 6:** Both part numbers of the LM74 will operate properly over the  $V^+$  supply voltage range of 3V to 5.5V. The devices are tested and specified for rated temperature error at their nominal supply voltage for temperature ranges of  $-10^\circ\text{C}$  to  $+65^\circ\text{C}$ ,  $-55^\circ\text{C}$  to  $+125^\circ\text{C}$  and  $-55^\circ\text{C}$  to  $+150^\circ\text{C}$ . The temperature error for temperature ranges of  $-40^\circ\text{C}$  to  $+85^\circ\text{C}$ ,  $-25^\circ\text{C}$  to  $+110^\circ\text{C}$  and  $-40^\circ\text{C}$  to  $+110^\circ\text{C}$  include error induced by power supply variation of  $\pm 5\%$  from the nominal value. Temperature error will increase by  $\pm 0.3^\circ\text{C}$  for a power supply voltage ( $V^+$ ) variation of  $\pm 10\%$  from the nominal value.

**Note 7:** Typicals are at  $T_A = 25^\circ\text{C}$  and represent most likely parametric norm.

**Note 8:** Limits are guaranteed to National's AOQL (Average Outgoing Quality Level).

**Note 9:** This specification is provided only to indicate how often temperature data is updated. The LM74 can be read at any time without regard to conversion state (and will yield last conversion result). A conversion in progress will not be interrupted. The output shift register will be updated at the completion of the read and a new conversion restarted.

**Note 10:** For best accuracy, minimize output loading. Higher sink currents can affect sensor accuracy with internal heating. This can cause an error of  $0.64^\circ\text{C}$  at full rated sink current and saturation voltage based on junction-to-ambient thermal resistance.

## Electrical Characteristics

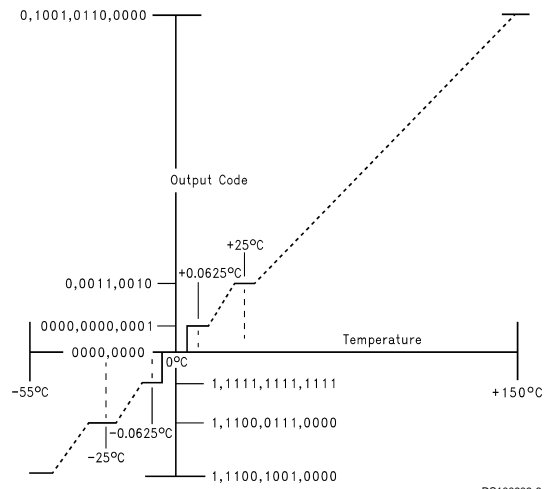

DS100909-8

FIGURE 5. Temperature-to-Digital Transfer Function (Non-linear scale for clarity)

## TRI-STATE Test Circuit

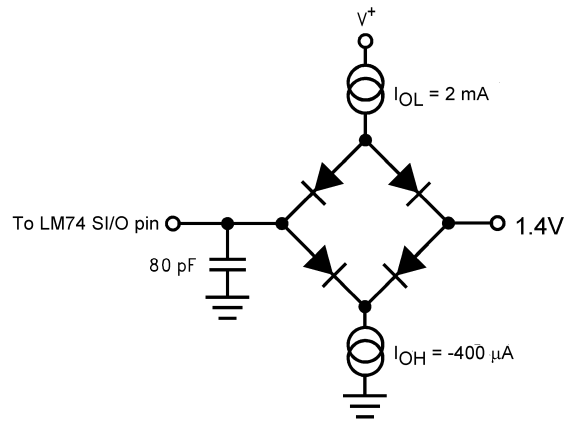

DS100909-7

## Typical Performance Characteristics

**Average Power-On Reset Voltage vs Temperature**

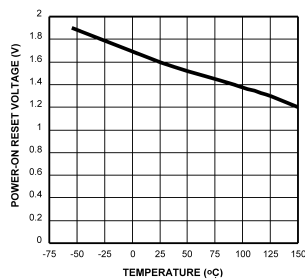

DS100909-23

**Static Supply Current vs Temperature**

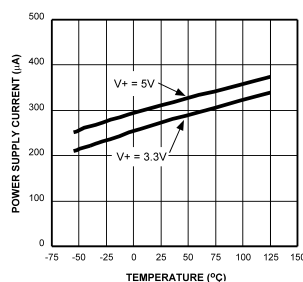

DS100909-21

**Temperature Error**

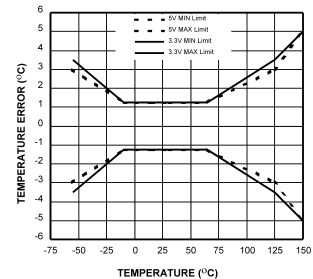

DS100909-22

## 1.0 Functional Description

The LM74 temperature sensor incorporates a band-gap type temperature sensor and 12-bit plus sign  $\Delta\Sigma$  ADC (Delta-Sigma Analog-to-Digital Converter). Compatibility of the LM74's three wire serial interface with SPI and MICROWIRE allows simple communications with common microcontrollers and processors. Shutdown mode can be used to optimize current drain for different applications. A Manufacturer's/Device ID register identifies the LM74 as National Semiconductor product.

### 1.1 POWER UP AND POWER DOWN

The LM74 always powers up in a known state. The power up default condition is continuous conversion mode. Immediately after power up the LM74 will output an erroneous code until the first temperature conversion has completed.

When the supply voltage is less than about 1.6V (typical), the LM74 is considered powered down. As the supply voltage rises above the nominal 1.6V power up threshold, the internal registers are reset to the power up default state described above.

### 1.2 SERIAL BUS INTERFACE

The LM74 operates as a slave and is compatible with SPI or MICROWIRE bus specifications. Data is clocked out on the falling edge of the serial clock (SC), while data is clocked in on the rising edge of SC. A complete transmit/receive communication will consist of 32 serial clocks. The first 16 clocks comprise the transmit phase of communication, while the second 16 clocks are the receive phase.

When  $\overline{CS}$  is high SI/O will be in TRI-STATE®. Communication should be initiated by taking chip select ( $\overline{CS}$ ) low. This should not be done when SC is changing from a low to high state. Once  $\overline{CS}$  is low the serial I/O pin (SI/O) will transmit the first bit of data. The master can then read this bit with the rising edge of SC. The remainder of the data will be clocked out by the falling edge of SC. Once the 14 bits of data (one sign bit, twelve temperature bits and 3 high bits) are transmitted the SI/O line will go into TRI-STATE.  $\overline{CS}$  can be taken high at any time during the transmit phase. If  $\overline{CS}$  is brought low in the middle of a conversion the LM74 will complete the conversion and the output shift register will be updated after  $\overline{CS}$  is brought back high.

The receive phase of a communication starts after 16 SC periods.  $\overline{CS}$  can remain low for 32 SC cycles. The LM74 will read the data available on the SI/O line on the rising edge of

the serial clock. Input data is to an 8-bit shift register. The part will detect the last eight bits shifted into the register. The receive phase can last up to 16 SC periods. All ones must be shifted in order to place the part into shutdown. A zero in any location will take the LM74 out of shutdown. The following codes should only be transmitted to the LM74:

- 00 hex
- 01 hex
- 03 hex
- 07 hex
- 0F hex
- 1F hex
- 3F hex
- 7F hex
- FF hex

any others may place the part into a Test Mode. Test Modes are used by National Semiconductor to thoroughly test the function of the LM74 during production testing. Only eight bits have been defined above since only the last eight transmitted, before  $\overline{CS}$  is taken HIGH, are detected by the LM74.

The following communication can be used to determine the Manufacturer's/Device ID and then immediately place the part into continuous conversion mode. With  $\overline{CS}$  continuously low:

- Read 16 bits of temperature data
- Write 16 bits of data commanding shutdown
- Read 16 bits of Manufacturer's/Device ID data
- Write 8 to 16 bits of data commanding Conversion Mode
- Take  $\overline{CS}$  HIGH.

Note that 250 ms will have to pass for a conversion to complete before the LM74 actually transmits temperature data.



## 1.0 Functional Description (Continued)

### 1.3 TEMPERATURE DATA FORMAT

Temperature data is represented by a 13-bit, two's complement word with an LSB (Least Significant Bit) equal to 0.0625°C:

Temperature	Digital Output	
	Binary	Hex
+150°C	0100 1011 0000 0111	4B 07h
+125°C	0011 1110 1000 0111	3E 87h
+25°C	0000 1100 1000 0111	0B 87h
+0.0625°C	0000 0000 0000 1111	00 0Fh
0°C	0000 0000 0000 0111	00 07h
-0.0625°C	1111 1111 1111 1111	FF FFh
-25°C	1111 0011 1000 0111	F3 87h
-55°C	1110 0100 1000 0111	E4 87h

Note: The last two bits are TRI-STATE and depicted as one in the table.

The first data byte is the most significant byte with most significant bit first, permitting only as much data as necessary to be read to determine temperature condition. For instance, if the first four bits of the temperature data indicate an over-temperature condition, the host processor could immediately take action to remedy the excessive temperatures.

### 1.4 SHUTDOWN MODE/MANUFACTURER'S ID

Shutdown mode is enabled by writing XX FF to the LM74 as shown in *Figure 7c*. The serial bus is still active when the LM74 is in shutdown. Current draw drops to less than 10 µA between serial communications. When in shutdown mode the LM74 always will output 1000 0000 0000 0XX. This is the manufacturer's/Device ID information. The first 5-bits of the field (1000 0XXX) are reserved for manufacturer's ID.

### 1.5 INTERNAL REGISTER STRUCTURE

The LM74 has three registers, the temperature register, the configuration register and the manufacturer's/device identification register. The temperature and manufacturer's/device identification registers are read only. The configuration register is write only.

The temperature and manufacturer's/device identification registers are read only. The configuration register is write only.

#### 1.5.1 CONFIGURATION REGISTER

(Selects shutdown or continuous conversion modes):

(Write Only):

D15	D14	D13	D12	D11	D10	D9	D8	D7	D6	D5	D4	D3	D2	D1	D0
X	X	X	X	X	X	X	X	Shutdown							

D0–D15 set to XX FF hex enables shutdown mode.

D0–D15 set to 00 00 hex sets Continuous conversion mode.

Note: setting D0-D15 to any other values may place the LM70 into a manufacturer's test mode, upon which the LM74 will stop responding as described. These test modes are to be used for National Semiconductor production testing only. See Section 1.2 Serial Bus Interface for a complete discussion.

#### 1.5.2 TEMPERATURE REGISTER

(Read Only):

D15	D14	D13	D12	D11	D10	D9	D8	D7	D6	D5	D4	D3	D2	D1	D0
MSB	Bit 11	Bit 10	Bit 9	Bit 8	Bit 7	Bit 6	Bit 5	Bit 4	Bit 3	Bit 2	Bit 1	LSB	1	X	X

D0–D1: Undefined. TRI-STATE will be output on SI/O.

D2: Always set high.

D3–D15: Temperature Data. One LSB = 0.0625°C. Two's complement format.

#### 1.5.3 MANUFACTURER'S/DEVICE ID REGISTER

(Read Only):

D15	D14	D13	D12	D11	D10	D9	D8	D7	D6	D5	D4	D3	D2	D1	D0
1	0	0	0	0	0	0	0	0	0	0	0	0	0	X	X

D0–D1: Undefined. TRI-STATE will be output on SI/O.

D2–D15: Manufacturer's/Device ID Data. This register is accessed whenever the LM74 is in shutdown mode.

## 2.0 Serial Bus Timing Diagrams

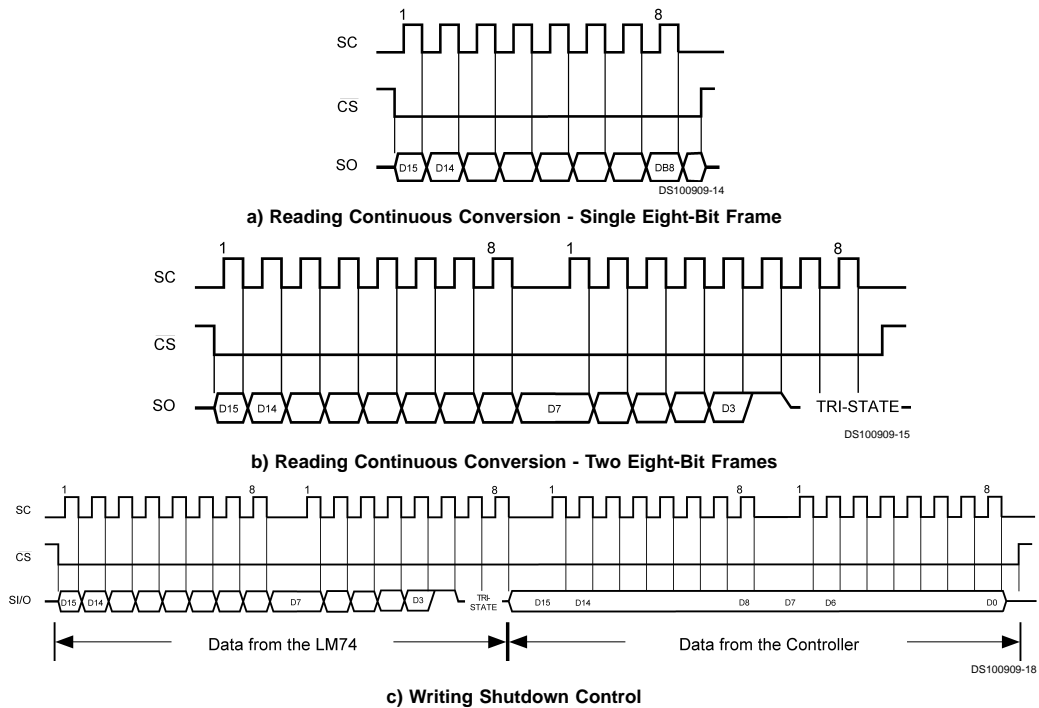

**FIGURE 7. Timing Diagrams**

## 3.0 Application Hints

To get the expected results when measuring temperature with an integrated circuit temperature sensor like the LM74, it is important to understand that the sensor measures its own die temperature. For the LM74, the best thermal path between the die and the outside world is through the LM74's pins. In the SO-8 package all the pins on the LM74 will have an equal effect on the die temperature. Because the pins represent a good thermal path to the LM74 die, the LM74 will provide an accurate measurement of the temperature of the printed circuit board on which it is mounted. There is a less efficient thermal path between the plastic package and the LM74 die. If the ambient air temperature is significantly different from the printed circuit board temperature, it will have a small effect on the measured temperature.

In probe-type applications, the LM74 can be mounted inside a sealed-end metal tube, and can then be dipped into a bath or screwed into a threaded hole in a tank. As with any IC, the LM74 and accompanying wiring and circuits must be kept insulated and dry, to avoid leakage and corrosion. This is especially true if the circuit may operate at cold temperatures where condensation can occur. Printed-circuit coatings and varnishes such as Humiseal and epoxy paints or dips are often used to insure that moisture cannot corrode the LM74 or its connections.

## 4.0 Typical Applications

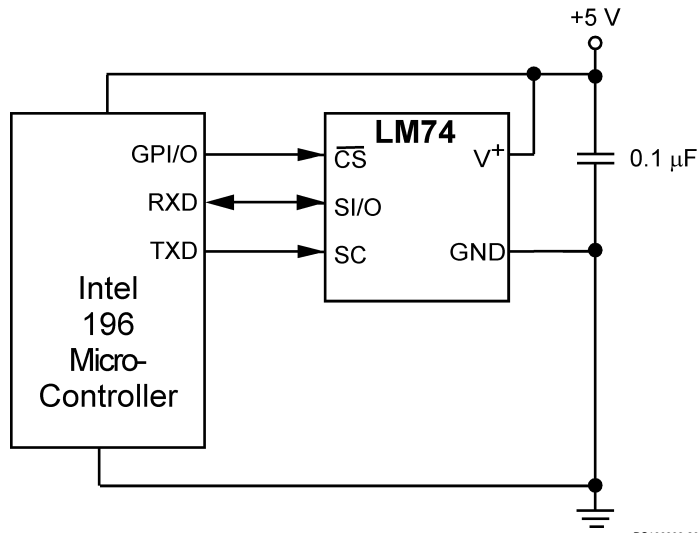

FIGURE 8. Temperature monitor using Intel 196 processor

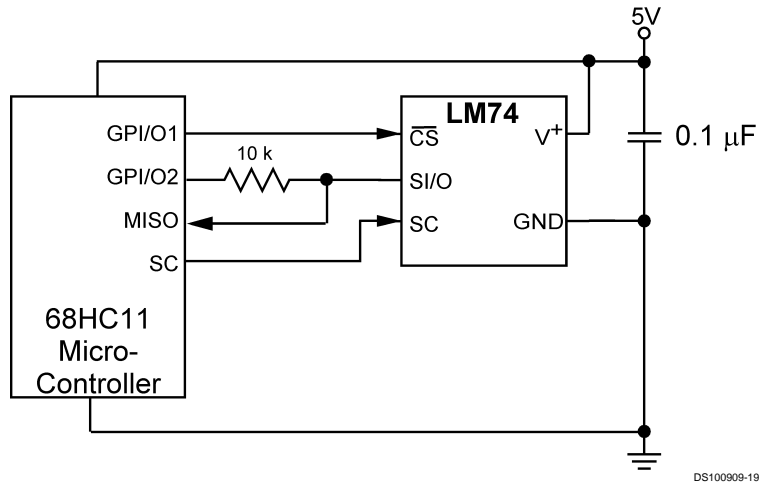
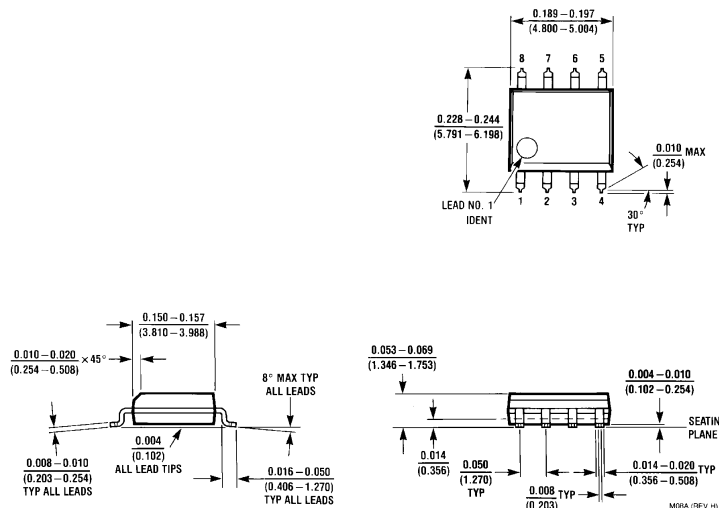

FIGURE 9. LM74 digital input control using micro-controller's general purpose I/O.

**Physical Dimensions** inches (millimeters) unless otherwise noted



**8-Lead Molded Small Outline Package**  
**Order Number LM74CIM-3, LM74CIMX-3, LM74CIM-5 or LM74CIMX-5**  
**NS Package Number M08B**

**LIFE SUPPORT POLICY**

NATIONAL'S PRODUCTS ARE NOT AUTHORIZED FOR USE AS CRITICAL COMPONENTS IN LIFE SUPPORT DEVICES OR SYSTEMS WITHOUT THE EXPRESS WRITTEN APPROVAL OF THE PRESIDENT AND GENERAL COUNSEL OF NATIONAL SEMICONDUCTOR CORPORATION. As used herein:

1. Life support devices or systems are devices or systems which, (a) are intended for surgical implant into the body, or (b) support or sustain life, and whose failure to perform when properly used in accordance with instructions for use provided in the labeling, can be reasonably expected to result in a significant injury to the user.
2. A critical component is any component of a life support device or system whose failure to perform can be reasonably expected to cause the failure of the life support device or system, or to affect its safety or effectiveness.



**National Semiconductor Corporation**  
 Americas  
 Tel: 1-800-272-9959  
 Fax: 1-800-737-7018  
 Email: support@nsc.com

www.national.com

**National Semiconductor Europe**  
 Fax: +49 (0) 1 80-530 85 86  
 Email: europe.support@nsc.com  
 Deutsch Tel: +49 (0) 1 80-530 85 85  
 English Tel: +49 (0) 1 80-532 78 32  
 Français Tel: +49 (0) 1 80-532 93 58  
 Italiano Tel: +49 (0) 1 80-534 16 80

**National Semiconductor Asia Pacific Customer Response Group**  
 Tel: 65-2544466  
 Fax: 65-2504466  
 Email: sea.support@nsc.com

**National Semiconductor Japan Ltd.**  
 Tel: 81-3-5639-7560  
 Fax: 81-3-5639-7507