

## Evaluation Board for the AD7710, 24-Bit Sigma Delta A/D Converter

by Mike Byrne and Albert O'Grady

### INTRODUCTION

This Application Note describes the evaluation board for the AD7710 24-Bit Signal Conditioning A/D converter. This converter utilizes sigma delta techniques to offer 16-bit accuracy (0.0015% FSR) and no missing codes to 24 bits. It contains a two-channel programmable gain front end, a programmable low-pass digital filter and a bidirectional serial interface. Both analog inputs and the reference input are differential and the part can accept inputs as low as 20 mV full-scale. It features a self-calibration mode, which removes internal offset and gain errors, a system calibration mode, which removes external circuit offset and gain errors, and a background calibration mode which automatically removes internal offset and gain errors. In addition, its flexible serial interface allows the AD7710 to connect directly to Digital Signal Processors (ADSP-2101, TMS320C25, etc.) and Microcontrollers (8XC51, 68HC11, etc.). Full data on the AD7710 is available in the AD7710 data sheet available from

Analog Devices and should be consulted in conjunction with this Application Note when using the Evaluation Board.

On-board components include an AD680, +2.5 V reference (the part's own +2.5V reference can also be used), a 10 MHz crystal (an external clock source can also be used) and bus buffers to facilitate the AD7710's two serial interface modes.

The basic evaluation board schematic is shown in Figure 1 while a full circuit diagram for the board is shown in Figure 3. The component silk screen, component side layout and solder side layout for the evaluation board are given in Figures 4, 5 and 6 respectively.

### LINK OPTIONS

The AD7710 Evaluation Board has several link options available to facilitate a variety of operating conditions and these are summarised in Table I. The position of the link options should be chosen before any power is applied to the evaluation board.

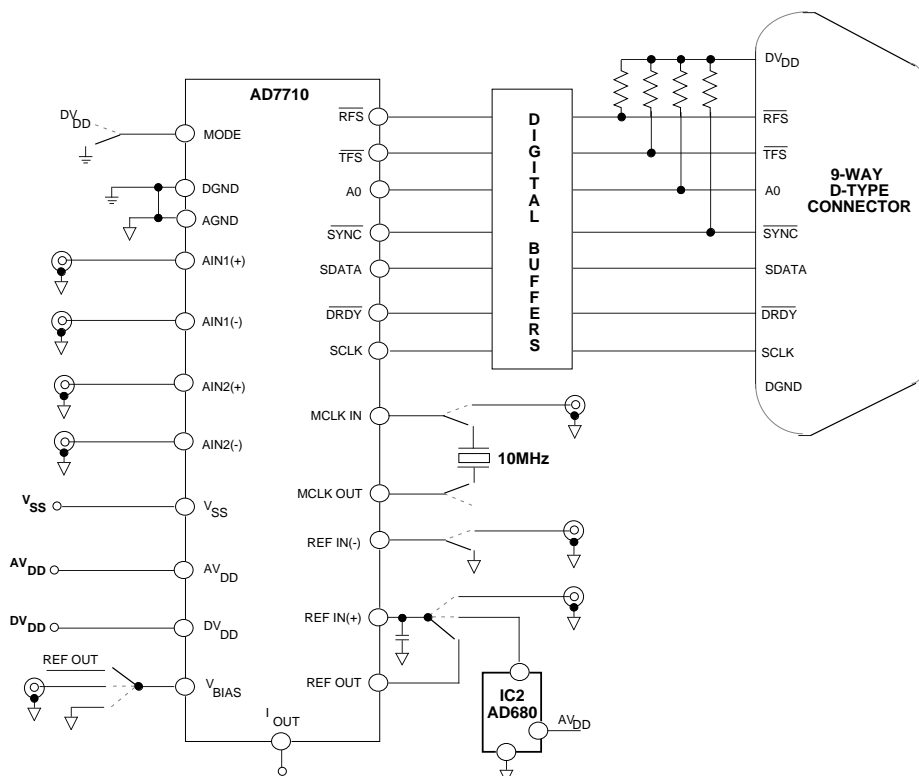

Figure 1. Evaluation Board Basic Schematic Diagram

Link No.	Function
LK1	<p>This option selects the serial interface mode for the AD7710. It is a double link (both links <b>must</b> be moved together for correct operation) which sets the AD7710 MODE pin and configures the bi-directional buffer on the serial clock.</p> <p>With both links in position A , the MODE input is low putting the device into its external clocking mode and the AD7710 SCLK pin is configured as an input and the serial clock buffer (74HC125) is configured as an input.</p> <p>With both links in position B , the MODE input is high putting the device into its self-clocking mode and the AD7710 SCLK pin is configured as an output and the serial clock buffer (74HC125) is also configured as an output.</p>
LK2	<p>This option selects the master clock source for the AD7710. The master clock source comes from the on-board crystal or from an external clock source via SKT6. It is a double link (both links <b>must</b> be moved together for correct operation).</p> <p>With both links in position A, the external clock is selected. The external clock for the AD7710 must be applied to SKT6 which is routed to the MCLK IN pin of the AD7710.</p> <p>With both links in position B, the on-board 10 MHz crystal (XTAL 1) provides the master clock for the device. With the links in this position, the crystal is connected between the MCLK IN and MCLK OUT pins of the AD7710.</p>
LK3	<p>This link is used to short out the resistor in the reference decoupling scheme. With this link option in place the reference decoupling resistor, R9, is shorted out. When the AD680 reference is used as the reference source for the device, this link option should not be in place. When using the AD7710's own internal reference or when using an external reference which does not require any decoupling resistor, this link should be in place.</p>
LK4	<p>This option is used to select the reference source for the AD7710's REF IN(+) pin.</p> <p>With this link in position A, the AD7710's own on-chip reference is used as the reference source for the AD7710 and REF OUT is connected directly to the REF IN(+) input.</p> <p>With this link in position B, the AD680 +2.5 V reference is used as the reference source for the AD7710 and the AD680's <math>V_{OUT}</math> pin is connected, via the decoupling components, to the REF IN(+) input.</p> <p>With this link in position C, an external reference, applied to SKT7, can be used as the reference source for the AD7710 and SKT7 is connected, via the decoupling components (see LK3), to the REF IN(+) input.</p>
LK5	<p>This option is used to select the voltage source for the AD7710's REF IN(-) pin.</p> <p>With this link in position A, the REF IN(-) pin of the AD7710 is connected directly to AGND. If the AD7710's own reference is used as the reference source for REF IN(+), REF IN(-) should be connected to AGND.</p> <p>With this link in position B, an external voltage, applied to SKT8, can be used as the reference source for the AD7710's REF IN(-) input and SKT8 is connected directly to the REF IN(-) input. If an external differential voltage is required for the AD7710 it should be applied between SKT7 and SKT8 with LK4 and LK5 set appropriately.</p>
LK6	<p>This option is used to select the voltage source for the AD7710's <math>V_{BIAS}</math> pin.</p> <p>With this link in position A, the AD7710's own on-chip reference is used as the voltage source for the <math>V_{BIAS}</math> input and REF OUT is connected directly to the <math>V_{BIAS}</math> input.</p> <p>With this link in position B, the <math>V_{BIAS}</math> input is connected directly to AGND.</p> <p>With this link in position C, an external voltage, applied to SKT9, can be used as the voltage source for the <math>V_{BIAS}</math> input and SKT9 is connected directly to the <math>V_{BIAS}</math> input.</p>
LK7-LK10	<p>These links are in series with the AIN1(+), AIN1(-), AIN2(+) and AIN2(-) analog inputs respectively.</p> <p>With link LK7 in place, SKT2 is connected directly to the AIN1(+) input. With LK8 in place, SKT3 is connected directly to the AIN1(-) input. With link LK9 in place, SKT4 is connected directly to the AIN2(+) input. With LK10 in place, SKT5 is connected directly to the AIN2(-) input. These links may be removed so that the input signals at SKT2 to SKT5 can be connected to the component grid for signal conditioning before being applied to the analog inputs of the AD7710.</p>
LK 11	<p>This link is used to short out the schottky diode, D1, on the <math>AV_{DD}</math> supply when the device is operated with <math>AV_{DD}</math> and <math>DV_{DD}</math> driven from the same supply. When <math>AV_{DD}</math> and <math>DV_{DD}</math> are driven from different supplies, and the short-circuit current capability of the <math>DV_{DD}</math> supply is too large for the schottky diode, D2, then link option LK11 should be removed placing diode D1 in series with the <math>AV_{DD}</math> line.</p>

Table I. Link Options

## POWER SUPPLIES AND GROUNDING

The AD7710 has three power supply inputs:  $AV_{DD}$ ,  $DV_{DD}$  and  $V_{SS}$ . The  $AV_{DD}$  range is from +5 V to +10 V,  $DV_{DD}$  is +5 V and  $V_{SS}$  is 0 V or -5 V. There is an additional requirement that  $AV_{DD} - V_{SS}$  must be less than 10.5 V. The evaluation board caters for all options by providing  $AV_{DD}$ ,  $DV_{DD}$  and  $V_{SS}$  inputs. If  $AV_{DD} = +5$  V and  $DV_{DD} = +5$  V, it is recommended that  $AV_{DD}$  and  $DV_{DD}$  are driven from the same +5 V supply to avoid any power sequencing issues. In applications where two separate supply voltages are required for  $AV_{DD}$  and  $DV_{DD}$ , the 10 $\Omega$  resistor, R10, and the SD103C Schottky diode, D2, provide protection for the AD7710. In applications where, the short-circuit current capability of the  $DV_{DD}$  supply is too large for the SD103C, link option LK11 should be removed placing diode D1 in series with the  $AV_{DD}$  line.

All supplies are decoupled to Ground with 10 $\mu$ F tantalum and 0.1 $\mu$ F ceramic disc capacitors. The  $AV_{DD}$  and  $V_{SS}$  supplies are decoupled to the AGND plane while the  $DV_{DD}$  supply is decoupled to the DGND plane. Power for the digital section of the board and the  $DV_{DD}$  pin of the AD7710 is routed separately from the power for the analog section and  $AV_{DD}$  on the AD7710. For systems using a single +5 V supply for  $AV_{DD}$  and  $DV_{DD}$ , the  $AV_{DD}$  and  $DV_{DD}$  input terminals should be connected together.

The evaluation board uses extensive ground planing to minimise any high frequency noise interference from the on-board clocks or any other sources. Once again, the ground planing for the analog section is kept separate from that for the digital section and they are joined only at the AD7710 AGND and DGND pins.

## ANALOG INPUT SECTION

The AD7710 provides two differential analog input channels. The analog inputs to the evaluation board are applied to the sub-miniature BNC connectors labelled SKT2, SKT3, SKT4 and SKT5. With links LK7 through LK10 in place these BNC connector inputs are routed directly to the AIN1(+), AIN1(-), AIN2(+) and AIN2(-) inputs of the AD7710. These links can be removed to allow the input signals at SKT2 to SKT5 to be routed to the component grid if input signal conditioning is required. There is also the option of placing R, C anti-aliasing filters on each analog input line. These anti-aliasing components are not provided with the board but the wire links can be removed on the analog input lines to insert resistors (these resistor positions are labelled R1 through R4 on the silk screen). There are also plated-through holes to allow insertion of capacitors on each line (these capacitor positions are labelled C11 through C14 on the silk screen).

## REFERENCE INPUT

The reference input for the AD7710 is a differential input with the reference voltage,  $V_{REF}$ , equal to the difference between the REF IN(+) pin and the REF IN(-) pin. The evaluation board allows the reference to be generated from three sources using link options, LK4 and LK5. Table II summarises the reference link options. There is an additional link, LK3, also used with the reference. When in place, LK3 shorts out the reference decoupling resistor, R9. This decoupling resistor is required when using the AD680's  $V_{OUT}$  pin as the reference source for REF IN (+). It may also be

required by external reference sources. The REF IN(+) input is decoupled to AGND via C15, a 0.1  $\mu$ F ceramic disc capacitor.

The first of the reference options is to derive the reference voltage from the AD7710's own internal reference. R9 can be shorted out using LK3 when REF OUT is driving REF IN(+). REF OUT provides a single-ended, +2.5 V reference which is referred to AGND. Therefore, when REF OUT is connected to REF IN(+), the REF IN(-) input should be connected to AGND via LK5. The second option is to use the AD680's  $V_{OUT}$  pin as the reference source for REF IN(+). In this case, LK3 should be removed. Once again, the AD680 provides a single-ended, +2.5 V reference which is referred to AGND. Therefore, when the AD680  $V_{OUT}$  pin is connected to REF IN(+), the REF IN(-) input should be connected to AGND via LK5.

The third option is to use an external voltage as the reference source for the part. This external reference voltage is applied to the evaluation board at SKT7. This external reference voltage can be single-ended (in which case REF IN(-) is connected to AGND via LK5) or it can be a differential voltage applied between SKT7 and SKT8. LK5 can route the voltage on SKT8 directly to the REF IN(-) input of the AD7710.

LK4 Position	LK5 Position	REF IN(+) Voltage	REF IN(-) Voltage
A	A	REF OUT	AGND
B	A	AD680 $V_{OUT}$	AGND
C	A	SKT7 I/P	AGND
C	B	SKT7 I/P	SKT8 I/P

Table II. Reference Link Options

## $V_{BIAS}$ INPUT

The  $V_{BIAS}$  input for the AD7710 provides the return path for most of the currents flowing in the analog modulator. It provides the bias point for much of the analog circuitry in the modulator. The limits on the  $V_{BIAS}$  voltage depend on the reference voltage and on the  $AV_{DD}$  and  $V_{SS}$  voltages. Consult the datasheet to ensure correct biasing. The evaluation board allows the  $V_{BIAS}$  voltage to be generated from three sources using link option, LK6. Table III summarises the  $V_{BIAS}$  link options.

The first of the options connects the  $V_{BIAS}$  input directly to the REF OUT pin of the AD7710. This connection point can be used for either single supply systems ( $V_{SS} = 0$  V) or dual supply systems ( $V_{SS} = -5$  V) with a  $V_{REF}$  of +2.5 V. The second option connects the  $V_{BIAS}$  input directly to AGND. This connection point can be used for dual supply systems with a  $V_{REF}$  of +2.5 V. The third option connects the  $V_{BIAS}$  input to SKT9 to allow an external bias voltage to be applied to the AD7710. Note, the  $V_{BIAS}$  input should be driven from a low impedance point.

LK6 Postion	V <sub>BIAS</sub> Input
A	REF OUT
B	AGND
C	SKT9 I/P

Table III V<sub>BIAS</sub> Link Options

The V<sub>BIAS</sub> voltage does have an effect on the AV<sub>DD</sub> power supply rejection performance of the AD7710. If the V<sub>BIAS</sub> voltage tracks the AV<sub>DD</sub> supply, it improves the power supply rejection from the AV<sub>DD</sub> supply line from 80 dB to 95 dB typ. Using an external zener diode, connected between the AV<sub>DD</sub> line and the V<sub>BIAS</sub> input, as the source for the V<sub>BIAS</sub> voltage gives the improvement in the AV<sub>DD</sub> power supply rejection performance.

### CLOCK GENERATION

There are two clock source options for the master clock for the AD7710 selected by link, LK2. This is a double link option and the device will not operate correctly unless both links of LK2 are in the same position. When both links are in position B, the on-board 10 MHz crystal oscillator is connected between the MCLK IN and MCLK OUT pins of the AD7710 and this generates the master clock for the AD7710. With both links in position A, MCLK OUT is left open-circuit and MCLK IN is connected directly to SKT6. An external, CMOS-compatible, clock applied to SKT6 will provide the master clock for the AD7710. The frequency of this clock must be in the range from 400 kHz to 10 MHz. Note, for AV<sub>DD</sub> voltages in excess of +5.25 V, the AD7710 is only specified to operate with a master clock frequency of 8 MHz.

### AD7710 INTERFACE MODE SELECTION

The AD7710 may be set up for either of two serial interface modes. These are controlled on the evaluation board by link option LK1. This is a double link option and the device will not operate correctly in either of the modes unless both links of LK1 are in the same position. The modes are as follows:

1. The Self-Clocking Mode can be used with processors which allow an external device to clock their serial port including most digital signal processors and microcontrollers such as the 68HC11 and 68HC05. It also allows easy interfacing to serial-parallel conversion circuits, allowing interfacing to 74XX299 Universal Shift registers without any additional decoding. In this mode, the AD7710 acts as the master device in the serial system and data is clocked out of the part on the falling edge of the internally generated SCLK and is clocked into the device during the high time of the same internally-generated clock.
2. The External Clocking Mode, is designed for systems which provide a serial clock output which is synchronised to the serial data output including microcontrollers such as the 8XC51, 68HC11 and 68HC05 and most digital signal processors. In this mode, the

AD7710 acts as a slave device in the serial system and data is clocked out of the part on the falling edge of the externally-applied SCLK and is clocked into the device during the high time of the same externally-applied clock.

Table IV gives the link option positions for the interface modes. Note, inputs A0, SYNC, TFS and RFS all have 10kΩ pull-up resistors to DV<sub>DD</sub>.

LK1 Postion	Interface Mode
A	External-Clocking Mode
B	Self-Clocking Mode

Table IV. Interface Mode Selection

### EVALUATION BOARD INTERFACING

Interfacing to the evaluation board is via a 9-way D-Type connector, SKT1. The pinout for this connector is shown in Figure 2 and its pin designations are given in Table V. The port can be used in both the Self-Clocking Mode and the External Clocking Mode. The port has nine lines which are described below.

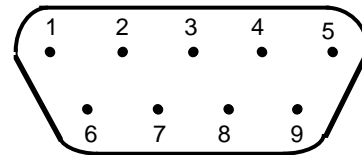

Figure 2. Pin Configuration for SKT1, D-Type Connector

PIN No.	Mnemonic
1	SCLK
2	$\overline{\text{DRDY}}$
3	$\overline{\text{RFS}}$
4	$\overline{\text{TFS}}$
5	A0
6	DGND
7	SDATA
8	DV <sub>DD</sub>
9	$\overline{\text{SYNC}}$

Table V. SKT1 Pin Functions

**SCLK** Serial Clock Input/Output. When the device is operating in the External-Clocking Mode, the external serial clock is applied to this terminal and goes via IC3 (74HC125 Quadruple Bus Buffer) to the SCLK pin of the AD7710. When the device is operating in the Self-Clocking Mode, the internal serial clock of the AD7710 is routed to this terminal via IC3. The MODE line controls the direction of buffering on this SCLK line.

**DRDY** This output is the DRDY signal from the AD7710 buffered via IC4 (74HC4050 Hex Buffer).

**RFS** This buffered input controls the AD7710 RFS input and in conjunction with TFS controls the direction of the buffering on the SDATA line. This RFS input has a 10 kΩ pull-up resistor to DV<sub>DD</sub> so that the RFS line will be pulled-up to its inactive high state even if the RFS input terminal is unconnected.

**TFS** This buffered input controls the AD7710 TFS input and in conjunction with RFS controls the direction of the buffering on the SDATA line. This TFS input has a 10 kΩ pull-up resistor to DV<sub>DD</sub> so that the TFS line will be pulled-up to its inactive high state even if the TFS input terminal is unconnected.

**A0** This buffered input controls the AD7710 A0 input. This A0 input has a 10 kΩ pull-up resistor to DV<sub>DD</sub> so that the A0 line will be pulled-up to a logic high state even if the A0 input terminal is unconnected.

**DGND** Digital Ground. This line is connected to the digital ground plane on the evaluation board. It allows the user to provide the digital supply via the connector along with the other digital signals.

**SDATA** Serial Data Input/Output. When writing to the AD7710 (TFS is low), the external serial data is applied to this terminal and goes via IC3 (74HC125 Quadruple Bus Buffer) to the SDATA pin of the AD7710. When reading from the AD7710 (RFS is low), the internal serial data output of the AD7710 is routed to this terminal via IC3.

**DV<sub>DD</sub>** Digital +5 V Supply. This line is connected to the DV<sub>DD</sub> supply line on the evaluation board. It allows the user to provide the digital supply via the connector along with the other digital signals.

**SYNC** This buffered input controls the AD7710 SYNC input. This SYNC input has a 10 kΩ pull-up resistor to DV<sub>DD</sub> so that the SYNC line will be pulled-up to its inactive high state even if the SYNC input terminal is unconnected.

## SOCKETS

There are nine sockets on the evaluation board. The function of these sockets is outlined in Table VI.

Socket	Function
SKT1	9 Way D-Type Connector
SKT2-SKT5	Sub-Minature BNC Sockets for analog inputs
SKT6	Sub-Minature BNC Socket for external master clock
SKT7	Sub-Minature BNC Socket for external REF IN(+)
SKT8	Sub-Minature BNC Socket for external REF IN(-)
SKT9	Sub-Minature BNC Socket for external V <sub>BIAS</sub>

Table VI. Socket Functions

## SET-UP CONDITIONS

Care should be taken before applying power and signals to the evaluation board to ensure that all link positions are as per the required operating mode. Figure 4 gives the physical layout of all the links on the board in order to ease set-up. Table VII gives the positions in which the links are set when the evaluation board is sent out.

Link	Initial Position
LK1	Double-Link in Position A, setting board for External Clocking Mode
LK2	Double Link in Position B, generating AD7710 master clock from Crystal Oscillator
LK3	Link in place, shorting out R9
LK4	Link in Position A, connecting REF IN(+) to REF OUT
LK5	Link in Position A, connecting REF IN(-) to AGND
LK6	Link in Position A, connecting V <sub>BIAS</sub> to REF OUT
LK7	Link in place, connecting SKT2 to AIN1(+)
LK8	Link in place, connecting SKT3 to AIN1(-)
LK9	Link in place, connecting SKT4 to AIN2(+)
LK10	Link in place, connecting SKT5 to AIN2(-)
LK11	Link not in place, therefore, D1 is in series with the AV <sub>DD</sub> line

Table VII. Initial Link Positions

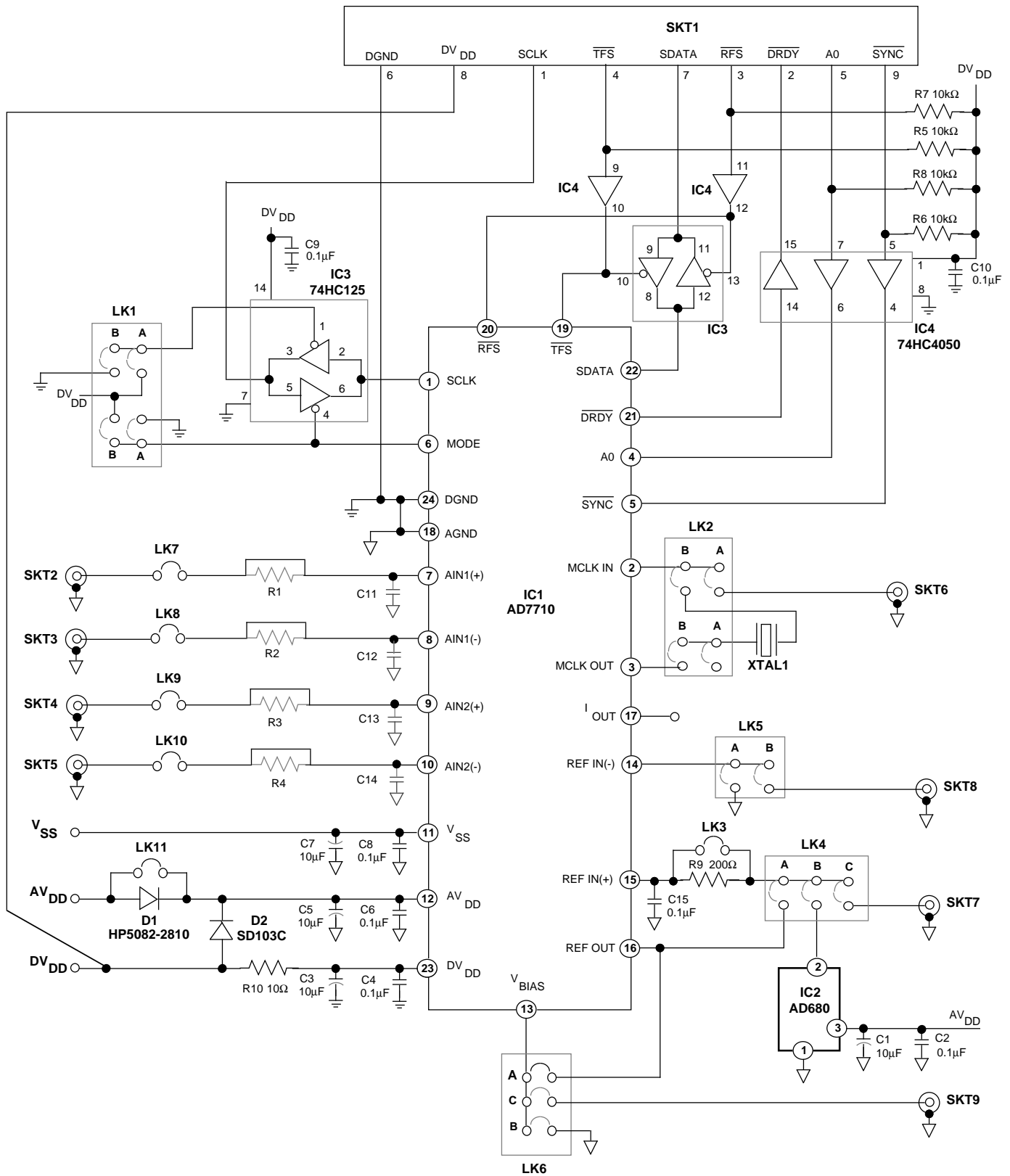

Figure 3. AD7710 Evaluation Board Circuit Diagram

## COMPONENT LIST

### Integrated Circuits

IC1	AD7710
IC2	AD680 Voltage Reference.
IC3	74HC125 Quad Bus Buffers with Three State Outputs.
IC4	74HC4050 Hex Buffer.

### Capacitors

C1,C3,C5,C7	10 $\mu$ F Capacitors.
C2,C4,C6, C8,C9,C10, C15	0.1 $\mu$ F Capacitors.

### Resistors

R5,R6,R7,R8	10k $\Omega$ Pull Up Resistors.
R9	200 $\Omega$ Resistor.
R10	10 $\Omega$ Resistor.

### Optional Filter Components

R1 C11,R2 C12, R3 C13,R4 C14	Can be used on Analog Inputs for filtering. Not included on board.
---------------------------------	--

### Crystals

XTAL 1	10 MHz Crystal.
--------	-----------------

### Links

LK1,LK2,LK3, LK4,LK5,LK6, LK7, LK8,LK9 LK10,LK11.	Shorting Plugs.
--	-----------------

### Sockets

SKT1	9-Way D Type Connector.
SKT2 to SKT9	Sub-Minature BNC Sockets.

### Diodes

D1	HP5082-2810, Schottky Diode.
D2	SD103C, Schottky Diode.

Figure 4. AD7710 Evaluation Board Silk Screen

*Figure 5. PCB Component Side Layout for Figure 3*

*Figure 6. PCB Solder Side Layout for Figure 3*